

# FT SERIES

**HIGH FORCE ROLLER SCREW ACTUATOR**

**Mount virtually any servo motor**

**Long stroke lengths available**

**High speed and long life**

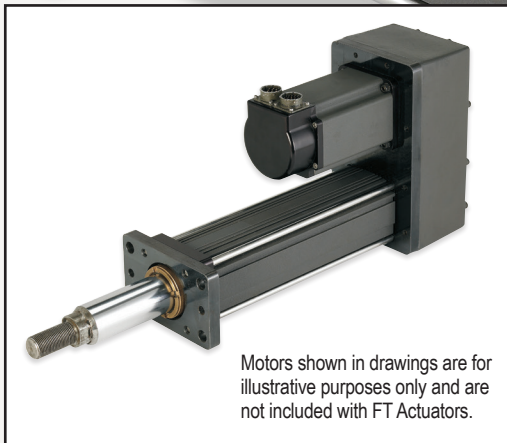
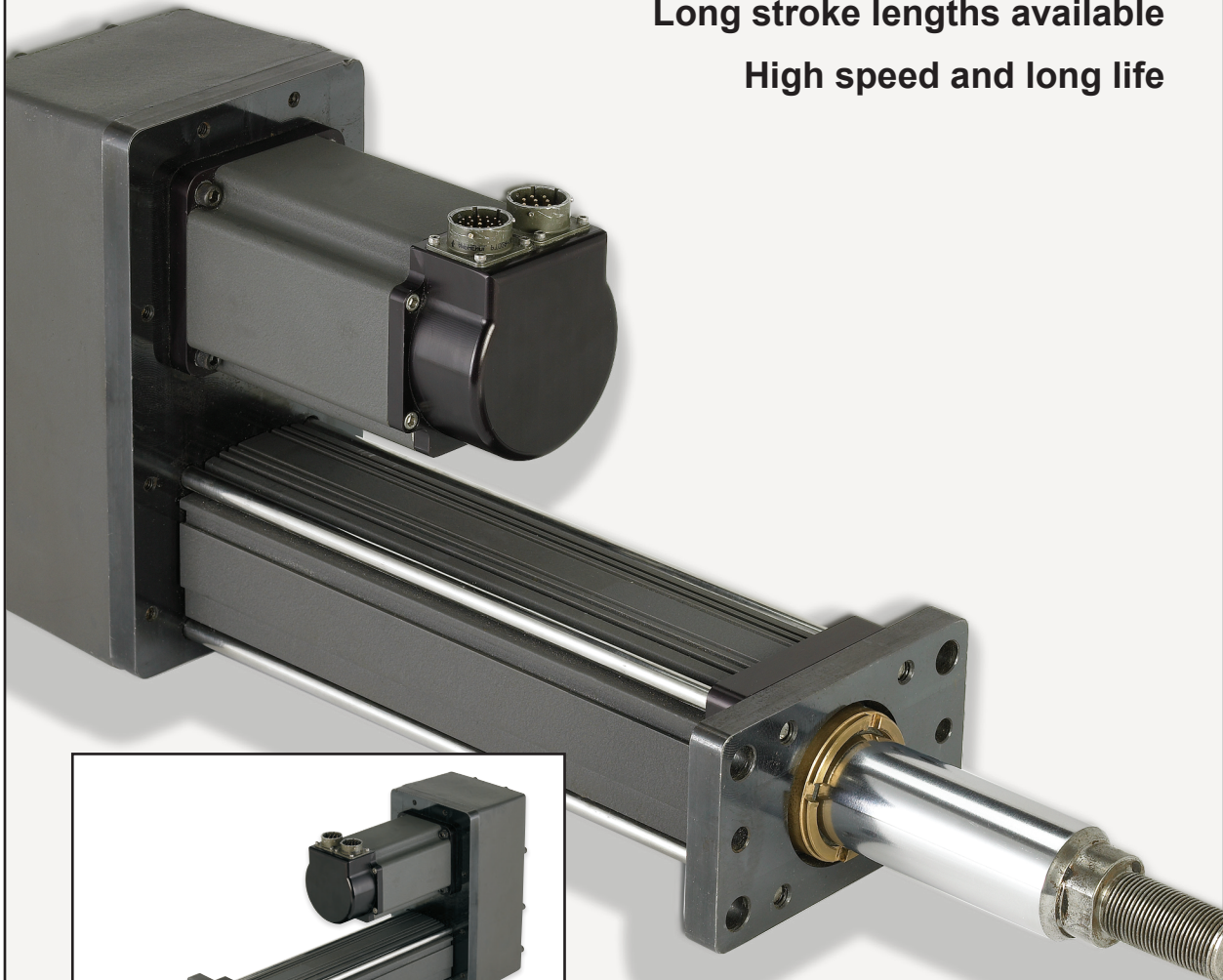

Motors shown in drawings are for illustrative purposes only and are not included with FT Actuators.

## FT Series

### Linear Actuators

#### High Performance

As with all Exlar roller screw products, the FT Series actuators deliver heavy load capacity, high speed capabilities, and exceptionally long life when compared to other linear actuator technologies.

Other comparably-sized screw actuator products on the market, specifically ball screw and acme screw actuators, have relatively low load capacities, short working lives and limited speed capabilities. At equivalent sizes, under moderate to heavy loads, it is reasonable to project that FT units will deliver up to 15 times the working life of those other methods. For OEM designers, this often means much more power and durability can be achieved from a much smaller footprint when Exlar FT units are used.

#### Contamination Protection

The FT Series design has all the contamination-isolation advantages of hydraulic cylinders without the limited load, life, and speed of designs built around ball or acme screws. The bearing and roller screw components in the Exlar FT Series force tubes are mounted within the sealed housing. This prevents abrasive particles and other contaminants from entering the actuator's critical mechanisms, and assures trouble-free operation even in the most severe environments.

FT Series actuators are provided with standard grease lubrication. Custom provisions can be made for oil filled lubrication.

Feature	Standard
Long Strokes	6 inch, 12 inch, 18 inch, 24 inch, 36 inch, and 48 inch
Multiple Actuator Mountings	Side Mount, Side Lug, Extended Tie Rods, Rear Clevis, Front Flange, Side Trunnion, Rear Flange, Front/Rear Flange
Multiple Motor Mounting Configurations	Inline Direct Drive, Parallel 1:1 Drive, Parallel, 2:1 Reduction

#### Engineered Compatibility

Exlar has removed much of the end-user-engineering burden by designing the FT series to be compatible with a wide variety of standard motors. Motor mounting, actuator mounting, and gearing configurations are available to meet nearly any application's requirements.

Exlar FT Series force tube actuators use a planetary roller screw mounted inside a tube mechanism. The follower is attached to the moveable force tube, which then extends and retracts as the screw rotates. An external motor (supplied by Exlar or the customer) provides the rotational force.

Technical Characteristics	
Frame Sizes - in (mm)	3.5 (90), 4.7 (120), 5.9 (150), 7.9 (200)
Screw Leads - in (mm)	0.2 (5), 0.25 (6), 0.4 (10), 0.5 (12), 0.8 (20), 1.2 (30)
Standard Stroke Lengths in (mm)	6 (152)*, 12 (305), 18 (457), 24 (610), 36 (914), 48 (1219)
Force Range	up to 40,000 lbf (178 kN)
Maximum Speed	up to 60 in/sec (1524 mm/s)

\*Not on FT60 or FT80

Operating Conditions and Usage		
<b>Accuracy:</b>		
Screw Lead Error	in/ft ( $\mu\text{m}$ / 300 mm)	0.001 (25)
Screw Travel Variation	in/ft ( $\mu\text{m}$ / 300 mm)	0.0012 (30)
Screw Lead Backlash*	in (mm)	0.002 (0.06)
Friction Torque Values	lbf-in (Nm)	FT35: 7.0 (0.79) FT45: 11.00 (1.24) FT60: 14.0 (1.58) FT80: 35.0 (3.95)
<b>Efficiency:</b>		
Motor Inline	%	80
Motor Parallel	%	80
Ambient Conditions:		
Standard Ambient Temperature	°C	0 to 65
Extended Ambient Temperature***	°C	-30 to 65
Storage Temperature	°C	-40 to 85
IP Rating**		IP65

\* System backlash will be different with various types of motor mounting arrangements and couplings. Please discuss your particular configuration with your local sales representative.

\*\* For IP65S sealing of unit with motor mounted, please contact your local sales representative.

\*\*\* Consult Exlar for extended temperature operation.

# FT Series Linear Actuators

## Product Features

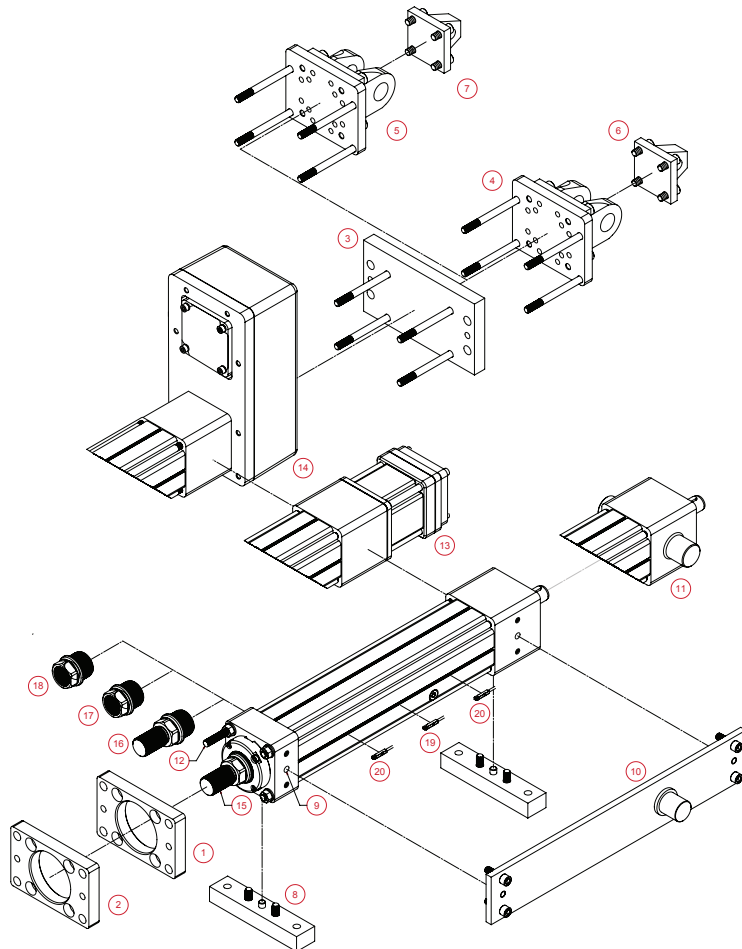
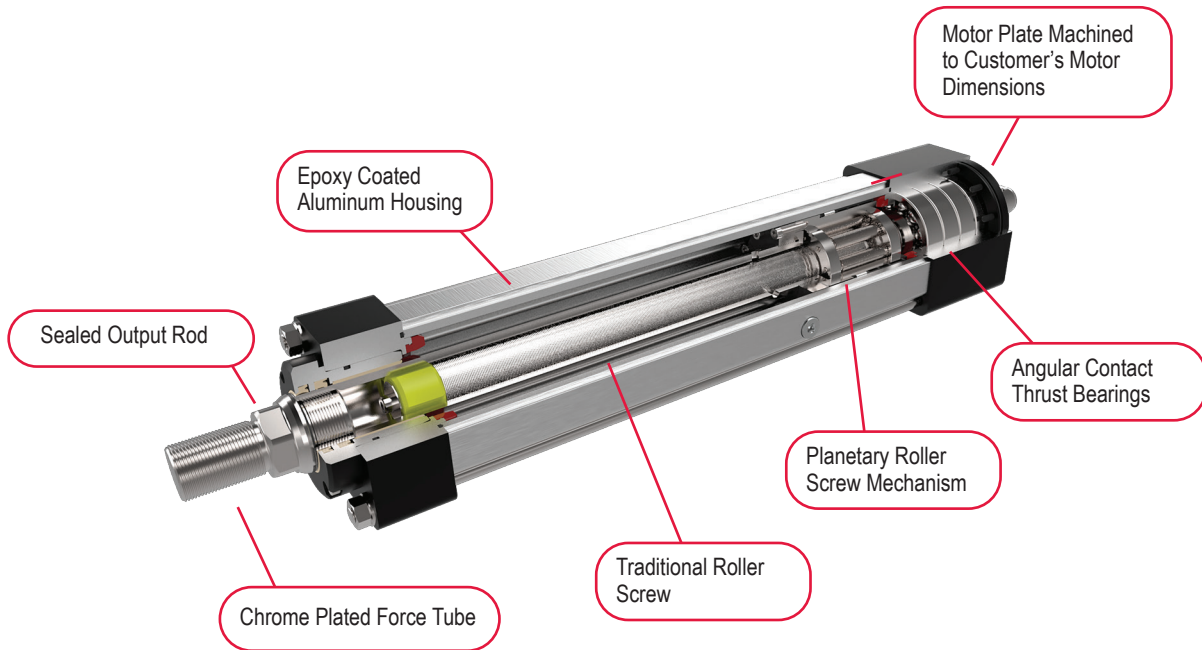

- 1 - Front flange, English
- 2 - Front flange, metric
- 3 - Rear flange, English
- 4 - Rear clevis, English
- 5 - Rear clevis, metric
- 6 - Rear eye English
- 7 - Rear eye, metric
- 8 - Side Lug Mount
- 9 - Double side mount and metric double side mount
- 10 - Side trunnion and metric side trunnion
- 11 - Rear trunnion and metric rear trunnion
- 12 - Extended tie rods and metric extended tie rods
- 13 - In-line direct drive
- 14 - Parallel, 1:1 belt reduction  
Parallel, 2:1 belt reduction
- 15 - Male, US standard thread
- 16 - Male, metric thread
- 17 - Female, US standard thread
- 18 - Female, metric thread
- 19 - External limit switch - N.O., PNP or NPN
- 20 - External limit switch - N.C., PNP or NPN

## Industries and Applications

Hydraulic cylinder replacement  
Ball screw replacement  
Pneumatic cylinder replacement

### Automotive

Lift station  
Automated assembly  
Riveting / fastening / joining  
Pressing

### Sawmill/Forestry

Saw positioning  
Fence positioning

### Process Control

Conveyor diverters / gates  
Precision valve control  
Tension control

### Machining

Automated flexible fixturing  
Machine tool  
Parts clamping  
Precision grinders

### Entertainment / Simulation

Action simulators  
Ride automation

### Material Handling

Stamping  
Indexing stages  
Product sorting  
Material cutting  
Web guidance  
Wire winding  
Pressing  
Tube bending

### Test

Test stands

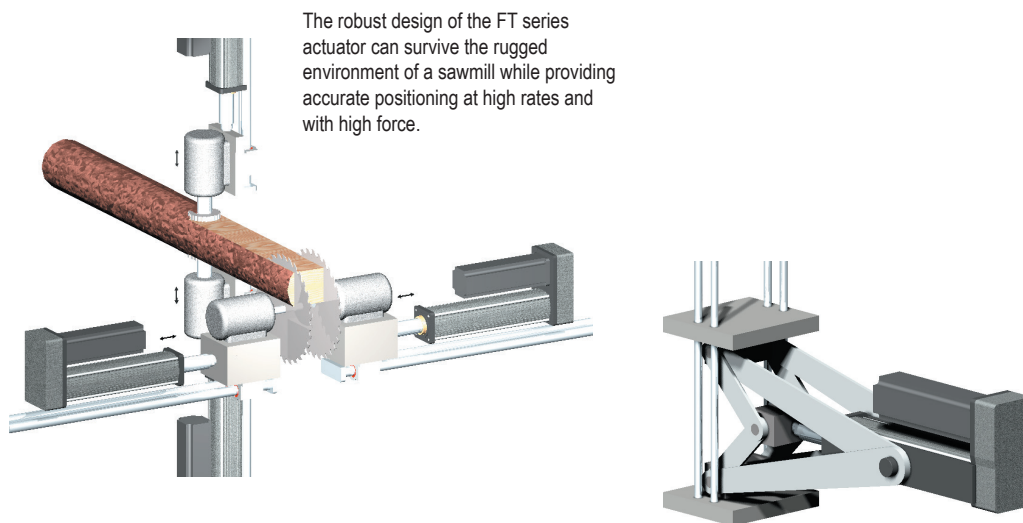

The robust design of the FT series actuator can survive the rugged environment of a sawmill while providing accurate positioning at high rates and with high force.

With their high thrust capability, compact size and smooth controlled motion, FT Series actuators are an ideal replacement for hydraulics or pneumatics on injection mold toggles. Control improvements from an electromechanical servo system offer less abuse of valuable molds and more consistent performance.

Motors shown in drawings are for illustrative purposes only and are not included with FT Actuators.

## Mechanical Specifications

### FT35

		High Capacity			Standard Capacity		
		05	10	20	05	10	20
Screw Lead	in	0.197	0.394	0.787	0.197	0.394	0.787
	mm	5	10	20	5	10	20
Maximum Force <sup>2</sup>	lbf	5,000	5,000	5,000	5,000	5,000	5,000
	kN	22.2	22.2	22.2	22.2	22.2	22.2
Estimated L <sub>10</sub> Life at Maximum Force	in x 10 <sup>6</sup>	15.4	24.6	56.7	8.88	14.15	32.05
	km	392	626	1,440	225.6	359.4	814.2
C <sub>a</sub> (Dynamic Load Rating)	lbf	21,400	19,850	20,800	17,800	16,500	17,200
	kN	95.2	88.3	92.5	79.2	73.4	76.5
Maximum Input Torque	lbf-in	196	392	783	196	392	783
	Nm	22.1	44.3	88.5	22.1	44.3	88.5
Max Rated RPM @ Input Shaft	RPM	4,500	4,500	4,500	4,500	4,500	4,500
Maximum Linear Speed @ Maximum Rated RPM	in/sec	14.7	29.5	59.3	14.7	29.5	59.3
	mm/sec	373	750	1,506	373	750	1,506

<sup>1</sup> FT35 actuators with high capacity screw option are 20 mm longer. See dimensions page 104.

<sup>2</sup> Maximum allowable actuator-generated force that can be applied routinely. Exceeding this force may result in permanent damage to the actuator. For high force, short stroke applications, consult factory.

## Weights kg (lbs)

Base Actuator Weight	Stroke Length	6 Inch	12 Inch	18 Inch	24 Inch	36 Inch	48 Inch
	lb		30	35	40	45	55
kg		14	16	18	21	25	30

Adder for Inline (excluding motor)	Adder for Parallel Drive (excluding motor)	Adder for Front Flange	Adder for Rear Flange	Adder for Rear Clevis	Adder for Rear Eye	Adder for Front/Rear Angle Mounts	Adder for Two Trunnions	Adder for Two Foot Mounts
8 (3.6)	16 (7.3)	5.4 (2.5)	7.4 (3.4)	3.0 (1.4)	NA	NA	19.5 (8.9)	3.3 (1.5)

FT35 Reflective Inertias	5 mm Lead	10 mm Lead	20 mm Lead	
NMT Unit - J (0)	0.0004087	0.0004121	0.0004259	kg-m <sup>2</sup> (at input shaft)
NMT Unit - J (Stroke)	0.0000159	0.0000162	0.0000171	kg-m <sup>2</sup> /inch of stroke
Inline w/ Coupler - J (0)	0.0005127	0.0005161	0.0005299	
Inline w/ Coupler - J (Stroke)	0.0000159	0.0000162	0.0000171	
Parallel 1:1 - J (0)	0.0011042	0.0011855	0.0014480	kg-m <sup>2</sup> (at motor shaft)
Parallel 1:1 - J (Stroke)	0.0000159	0.0000162	0.0000171	kg-m <sup>2</sup> /inch of stroke
Parallel 2:1 - J (0)	0.0014029	0.0014038	0.0015345	
Parallel 2:1 - J (Stroke)	0.0000040	0.0000040	0.0000043	

<sup>1</sup> Pulleys for parallel mount match actuator max performance ratings

Standard Inline Coupling Inertia	
FT35	<b>Inertia</b>
	0.000104 kg-m <sup>2</sup> (0.000920 lbf-in s <sup>2</sup> )

Pulley inertias reflected at motor including typical pulleys, belt and standard bushings. Because of differences in belt and pulley selection due to particular motor choices, please contact your local sales representative if these values are critical to your application.

Intermediate and custom stroke lengths are available. Belt and pulley inertia varies with ratio and motor selection. Please contact your local sales representative.

\*See definitions on page 100

## FT45

		High Capacity		Standard Capacity	
		05	10	05	10
Screw Lead	in	0.197	0.394	0.197	0.394
	mm	5	10	5	10
Maximum Force <sup>1</sup>	lbf	10,000	10,000	10,000	10,000
	kN	44.5	44.5	44.5	44.5
Estimated L <sub>10</sub> Life at Maximum Force	in x 10 <sup>6</sup>	9.81	19.14	5.67	11.06
	km	249.2	486.3	144.0	280.9
C <sub>a</sub> (Dynamic Load Rating)	lbf	36,800	36,500	30,650	30,400
	kN	163.7	162.4	136.3	135.2
Maximum Input Torque	lbf-in	392	783	392	783
	Nm	44.1	88.2	44.1	88.2
Max Rated RPM @ Input Shaft	RPM	3,500	3,500	3,500	3,500
Maximum Linear Speed @ Maximum Rated RPM	in/sec	11.5	23.0	11.5	23.0
	mm/sec	292	584	292	584

<sup>1</sup> Maximum allowable actuator-generated force that can be applied routinely. Exceeding this force may result in permanent damage to the actuator. For high force, short stroke applications, consult factory.

## Weights kg (lbs)

Base Actuator Weight	Stroke Length	6 Inch	12 Inch	18 Inch	24 Inch	36 Inch	48 Inch
	lb	57	68	79	90	112	135
	kg	26	31	36	41	51	61

Adder for Inline (excluding motor)	Adder for Parallel Drive (excluding motor)	Adder for Front Flange	Adder for Rear Flange	Adder for Rear Clevis	Adder for Rear Eye	Adder for Front/Rear Angle Mounts	Adder for Two Trunnions	Adder for Two Foot Mounts
7.1 (3.2)	42.5 (19.3)	6.1 (2.8)	17.4 (7.9)	18.9 (8.6)	19.8 (9)	NA	17.2 (7.8)	10.4 (4.7)

FT45 Reflective Inertias	5 mm Lead	10 mm Lead	
NMT Unit - J (0)	0.002463	0.002474	kg-m <sup>2</sup> (at input shaft)
NMT Unit - J (Stroke)	0.000045	0.000046	kg-m <sup>2</sup> /inch of stroke
Inline w/ Coupler - J (0)	0.002571	0.002581	kg-m <sup>2</sup> (at motor shaft) kg-m <sup>2</sup> /inch of stroke
Inline w/ Coupler - J (Stroke)	0.000045	0.000046	
Parallel 1:1 - J (0)	0.006911	0.006921	
Parallel 1:1 - J (Stroke)	0.000045	0.000046	
Parallel 2:1 - J (0)	0.003466	0.003469	
Parallel 2:1 - J (Stroke)	0.000011	0.000011	

<sup>†</sup>Pulleys for parallel mount match actuator max performance ratings

Standard Inline Coupling Inertia	
FT45	<b>Inertia</b>
	0.00010743 kg-m <sup>2</sup> (0.000951 lbf-in s <sup>2</sup> )

Pulley inertias reflected at motor including typical pulleys, belt and standard bushings. Because of differences in belt and pulley selection due to particular motor choices, please contact your local sales representative if these values are critical to your application.

\*See definitions on page 100

# FT Series Linear Actuators

## FT60

		High Capacity			Standard Capacity		
		06	12	30	06	12	30
Screw Lead	in	0.236	0.472	1.181	0.236	0.472	1.181
	mm	6	12	30	6	12	30
Maximum Force <sup>1</sup>	lbf	20,000	20,000	20,000	20,000	20,000	20,000
	kN	89.0	89.0	89.0	89.0	89.0	89.0
Estimated L <sub>10</sub> Life at Maximum Force	in x 10 <sup>6</sup>	5.7	7.3	38.6	4.1	5.2	10.7
	km	145.8	184.7	981.1	104.8	133.1	271.9
C <sub>a</sub> (Dynamic Load Rating)	lbf	57,933	49,750	63,958	51,900	44,600	41,700
	kN	257.7	221.3	284.5	230.9	198.4	185.5
Maximum Input Torque	lbf-in	940	1880	4699	940	1880	4699
	Nm	106	212	531	106	212	531
Max Rated RPM @ Input Shaft	RPM	2,000	2,000	2,000	2,000	2,000	2,000
Maximum Linear Speed @ Maximum Rated RPM	in/sec	7.9	15.8	39.0	7.9	15.8	39.0
	mm/sec	201	401	991	201	401	991

<sup>1</sup> Maximum allowable actuator-generated force that can be applied routinely. Exceeding this force may result in permanent damage to the actuator. For high force, short stroke applications, consult factory.

## Weights kg (lbs)

Base Actuator Weight	Stroke Length	12 inch	24 inch	36 inch	48 inch
	lb	100	130	160	190
	kg	45	59	72	86

Adder for Inline (excluding motor)	Adder for Parallel Drive (excluding motor)	Adder for Front Flange	Adder for Rear Flange	Adder for Rear Clevis	Adder for Rear Eye	Adder for Front/Rear Angle Mounts	Adder for Two Trunnions	Adder for Two Foot Mounts
20.4 (9.3)	39.1 (17.7)	13.4 (6.1)	15.9 (7.2)	11.1 (5)	NA	NA	44.3 (20.1)	10.4 (4.7)

FT60 Reflective Inertias	6 mm Lead	12 mm Lead	30 mm Lead	
NMT Unit - J (0)	0.0078464	0.0078709	0.0080424	kg-m <sup>2</sup> (at input shaft)
NMT Unit - J (Stroke)	0.0002539	0.0002547	0.0002600	kg-m <sup>2</sup> /inch of stroke
Inline w/ Coupler - J (0)	0.0081764	0.0082009	0.0083724	kg-m <sup>2</sup> (at motor shaft)
Inline w/ Coupler - J (Stroke)	0.0002539	0.0002547	0.0002600	
Parallel 1:1 - J (0)	0.0129357	0.0146113	0.0312682	kg-m <sup>2</sup> /inch of stroke
Parallel 1:1 - J (Stroke)	0.0002539	0.0002547	0.0002600	
Parallel 2:1 - J (0)	0.0049158	0.0057202	0.0214777	
Parallel 2:1 - J (Stroke)	0.0000635	0.0000637	0.0000650	

<sup>1</sup>Pulleys for parallel mount match actuator max performance ratings

Standard Inline Coupling Inertia	
FT60	<b>Inertia</b>
	0.000330 kg-m <sup>2</sup> (0.002921 lbf-in s <sup>2</sup> )

Pulley inertias reflected at motor including typical pulleys, belt and standard bushings. Because of differences in belt and pulley selection due to particular motor choices, please contact your local sales representative if these values are critical to your application.

Intermediate and custom stroke lengths are available. Belt and pulley inertia varies with ratio and motor selection. Please contact your local sales representative.

\*See definitions on page 100



## FT80

		High Capacity			Standard Capacity		
		06	12	30	06	12	30
Screw Lead	in	0.236	0.472	1.181	0.236	0.472	1.181
	mm	6	12	30	6	12	30
Maximum Force <sup>1</sup>	lbf	40,000	40,000	40,000	40,000	40,000	40,000
	kN	177.9	177.9	177.9	177.9	177.9	177.9
Estimated L <sub>10</sub> Life at Maximum Force	in x 10 <sup>6</sup>	3.1	4.4	16.3	1.94	2.55	5.00
	km	78.7	111.4	414.3	49.3	64.9	127
C <sub>a</sub> (Dynamic Load Rating)	lbf	94,330	84,079	95,971	80,700	70,200	64,700
	kN	419.6	374	426.9	359	312.2	287.8
Maximum Input Torque	lbf-in	1,880	3,760	9,399	1,880	3,760	9,399
	Nm	212	425	1,062	212	425	1,062
Max Rated RPM @ Input Shaft	RPM	1,750	1,750	1,750	1,750	1,750	1,750
Maximum Linear Speed @ Maximum Rated RPM	in/sec	6.9	13.8	34.4	6.9	13.8	34.4
	mm/sec	175	351	874	175	351	874

<sup>1</sup> Maximum allowable actuator-generated force that can be applied routinely. Exceeding this force may result in permanent damage to the actuator. For high force, short stroke applications, consult factory.

## Weights kg (lbs)

Base Actuator Weight	Stroke Length	12 Inch	24 Inch	36 Inch	48 Inch
	lb	190	265	340	415
	kg	86	120	153	187

Adder for Inline (excluding motor)	Adder for Parallel Drive (excluding motor)	Adder for Front Flange	Adder for Rear Flange	Adder for Rear Clevis	Adder for Rear Eye	Adder for Front/Rear Angle Mounts	Adder for Two Trunnions	Adder for Two Foot Mounts
54.9 (24.9)	79.1 (35.9)	28.5 (17.5)	NA	NA	NA	NA	NA	34.8 (15.8)

FT80 Reflective Inertias	6 mm Lead	12 mm Lead	30 mm Lead	
NMT Unit - J (0)	0.0302504	0.0303275	0.0308673	kg-m <sup>2</sup> (at input shaft)
NMT Unit - J (Stroke)	0.0008022	0.0008035	0.0008124	kg-m <sup>2</sup> /inch of stroke
Inline w/ Coupler - J (0)	0.0314604	0.0315375	0.0320773	kg-m <sup>2</sup> (at motor shaft)
Inline w/ Coupler - J (Stroke)	0.0008022	0.0008035	0.0008124	
Parallel 1:1 - J (0)	0.0721056	0.0535533	0.1342578	kg-m <sup>2</sup> /inch of stroke
Parallel 1:1 - J (Stroke)	0.0008022	0.0008035	0.0008124	
Parallel 2:1 - J (0)	0.0198765	0.0270490	0.0753395	
Parallel 2:1 - J (Stroke)	0.0002006	0.0002009	0.0002031	

<sup>†</sup>Pulleys for parallel mount match actuator max performance ratings

Standard Inline Coupling Inertia	
FT80	<b>Inertia</b>
	0.0001210 kg-m <sup>2</sup> (0.010709 lbf-in s <sup>2</sup> )

Pulley inertias reflected at motor including typical pulleys, belt and standard bushings. Because of differences in belt and pulley selection due to particular motor choices, please contact your local sales representative if these values are critical to your application.

Intermediate and custom stroke lengths are available. Belt and pulley inertia varies with ratio and motor selection. Please contact your local sales representative.

\*See definitions on page 100



# FT Series Linear Actuators

## DEFINITIONS:

**Maximum Force:** Calculated Cubic Mean Load for the application should not exceed this value. (Values are derived from the design capacity of the FT Series actuator and should not be exceeded or relied upon for continuous operation.)

**Life at Maximum Force:** Estimated life that can be expected from the actuator when running at Maximum Force for intermittent periods of time. (Theoretical calculation based on the Dynamic Load Rating of the actuator and using the Maximum Force rating as the Cubic Mean Load.)

**C<sub>s</sub> (Dynamic Load Rating):** A design constant used when calculating the estimated travel life of the roller screw.

**Maximum Input Torque:** The torque required at the screw to produce the Maximum Force rating. Exceeding this value can cause permanent damage to the actuator.

**Maximum Rated RPM:** The maximum allowable rotational screw speed determined by either screw length limitations or the rotational speed limit of the roller screw nut.

**Maximum Linear Speed:** The linear speed achieved by the actuator when Maximum Rated RPM is applied to the roller screw input shaft.

## FT Series Accessories

Limit Switches (if required in addition to L1, L2, L3 option in actuator model)			
FT35, FT60, FT80			
Option	Quantity	Part Number	Description
L1	1	14453	Normally Closed PNP Limit Switch (10-30 VDC, 1m. 3 wire embedded cable)
L2	2	14453	Normally Closed PNP Limit Switch (10-30 VDC, 1m. 3 wire embedded cable)
L3	3	14453	Normally Closed PNP Limit Switch (10-30 VDC, 1m. 3 wire embedded cable)
L4			NA
L5			NA
L6			NA
FT45			
L1	1	43403	Normally Open PNP Limit Switch (10-30 VDC, 1m. 3 wire embedded cable)
L2	2	43404	Normally Closed PNP Limit Switch (10-30 VDC, 1m. 3 wire embedded cable)
L3	1	43403	Normally Open PNP Limit Switch (10-30 VDC, 1m. 3 wire embedded cable)
	2	43404	Normally Closed PNP Limit Switch (10-30 VDC, 1m. 3 wire embedded cable)
L4	1	67634	Normally Open NPN Limit Switch (10-30 VDC, 1m. 3 wire embedded cable)
L5	2	67635	Normally Closed NPN Limit Switch (10-30 VDC, 1m. 3 wire embedded cable)
L6	1	67634	Normally Open NPN Limit Switch (10-30 VDC, 1m. 3 wire embedded cable)
	2	67635	Normally Closed NPN Limit Switch (10-30 VDC, 1m. 3 wire embedded cable)

Consult your local sales representative to discuss maximum stroke length allowable with your final configuration.

## Estimated Service Life

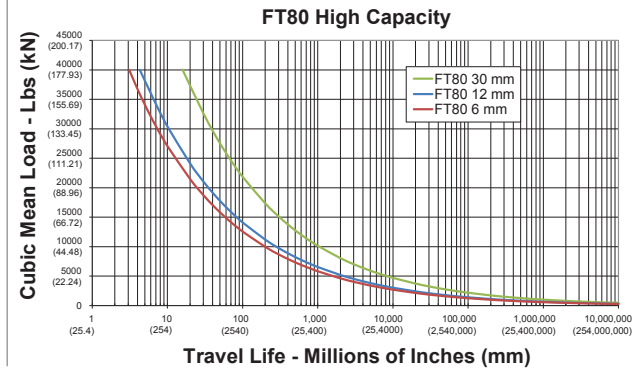
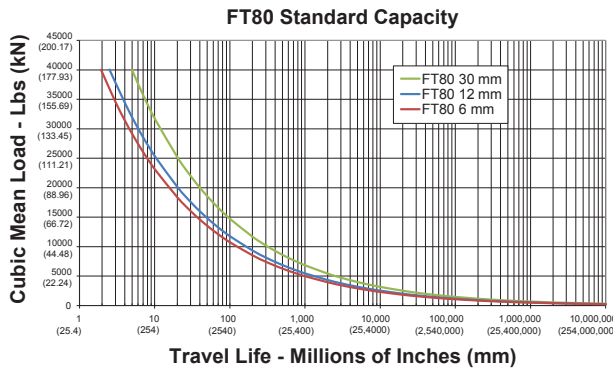
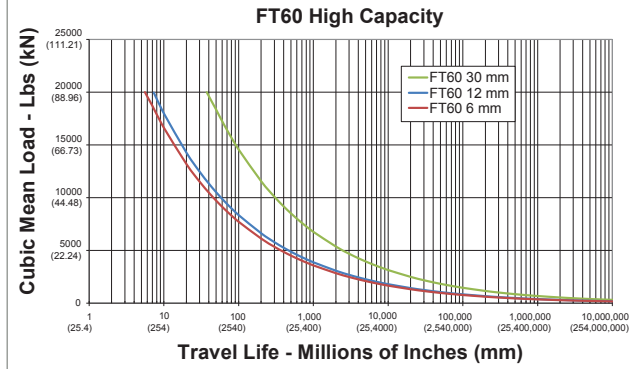
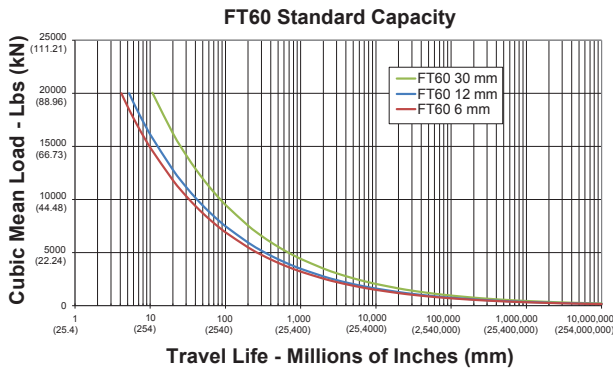
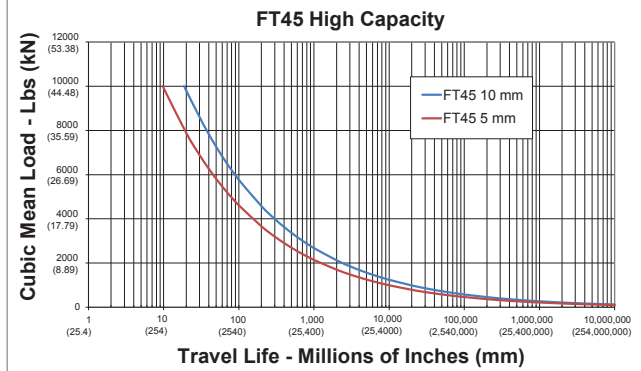
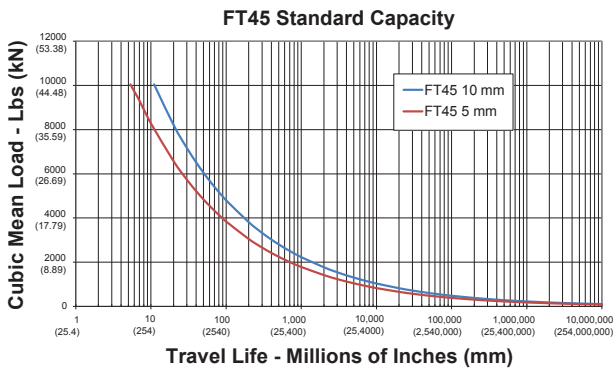
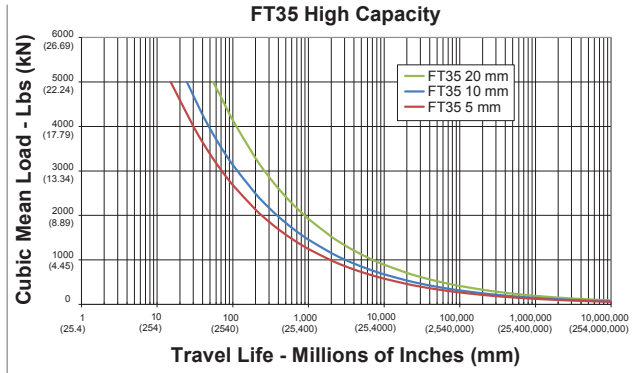
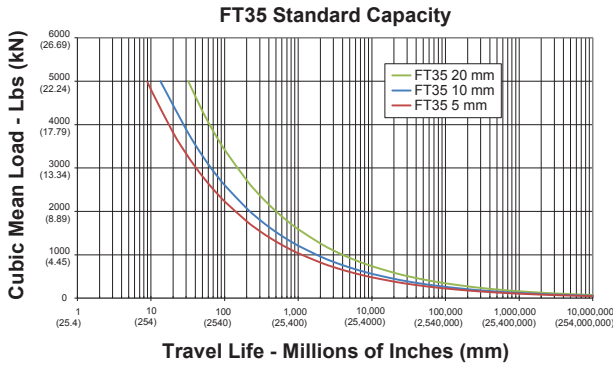

# FT Series Linear Actuators

## Service Life Estimate Assumptions:

- Sufficient quality and quantity of lubrication is maintained throughout service life (please refer to engineering reference on page 169 for lubrication interval estimates.)
- Bearing and screw temperature between 20° C and 40° C
- No mechanical hard stops (external or internal) or impact loads
- No external side loads
- Does not apply to short stroke, high frequency applications such as fatigue testing or short stroke, high force applications such as pressing. (For information on calculating estimating life for unique applications please refer to the engineering reference on page 169.

The  $L_{10}$  expected life of a roller screw linear actuator is expressed as the linear travel distance that 90% of properly maintained roller screws manufactured are expected to meet or exceed. This is not a guarantee and these charts should be used for estimation purposes only.

The underlying formula that defines this value is:  
Travel life in millions of inches, where:

$$L_{10} = \left( \frac{C_a}{F_{cml}} \right)^3 \times \ell$$

$C_a$  = Dynamic load rating (lbf)  
 $F_{cml}$  = Cubic mean applied load (lbf)  
 $\ell$  = Roller screw lead (inches)

For additional details on calculating estimated service life, please refer to the Engineering Reference, page 169.

## Data Curves

### Critical Speed vs Stroke Length:

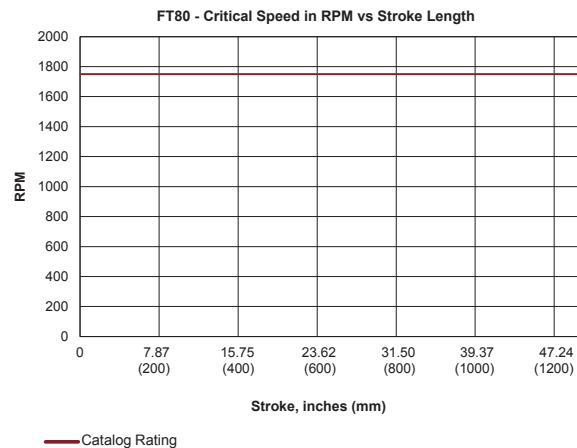
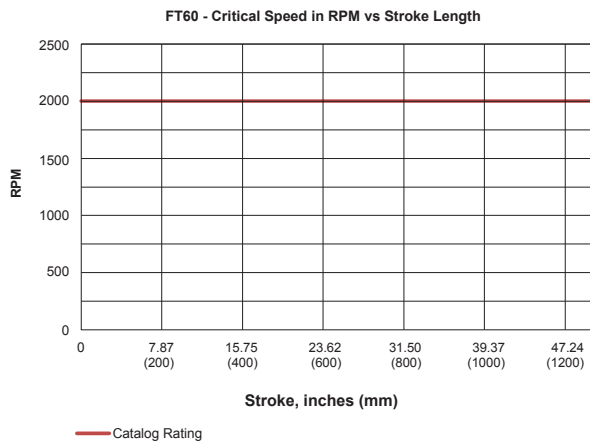
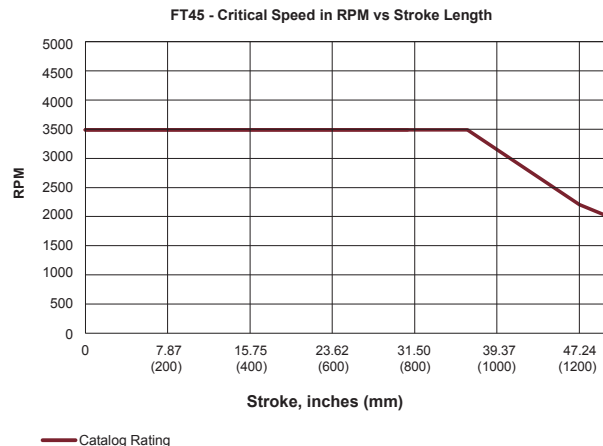
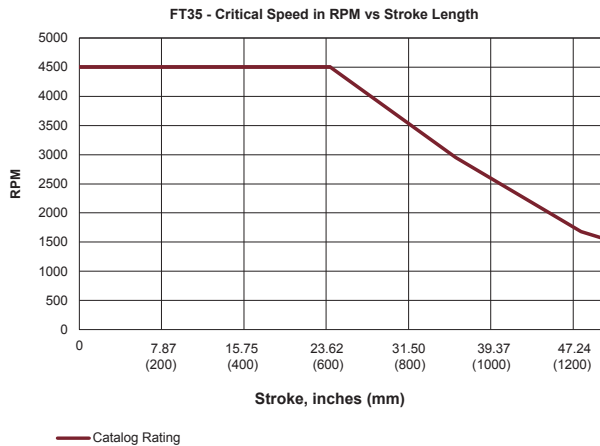

\* With longer stroke length actuators, the rated speed of the actuator is determined by the critical speed

## Maximum Force Rating

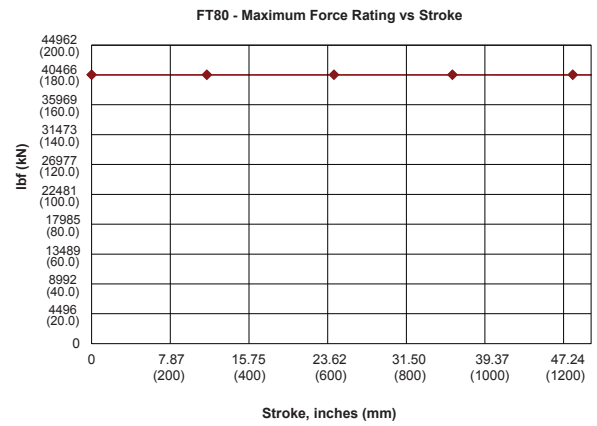
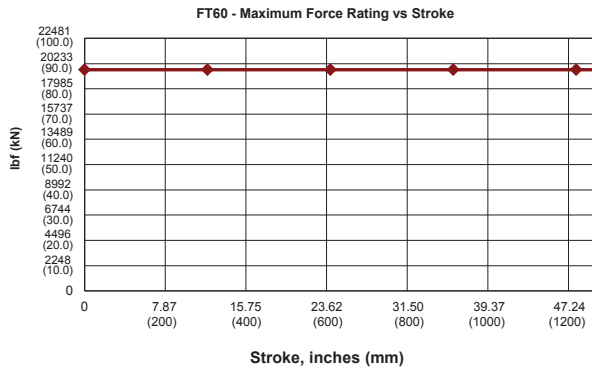
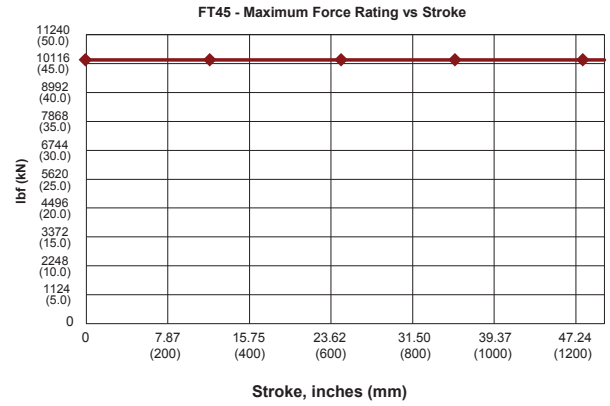
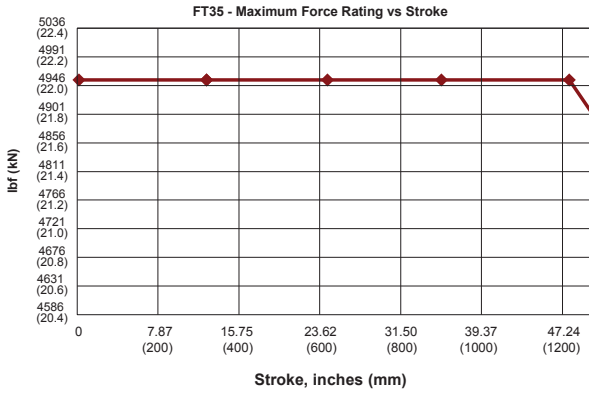

\* With longer stroke length actuators, the rated speed of the actuator is determined by the critical speed

# FT Series Linear Actuators

## Dimensions

### Base Actuator (FT35, FT60, FT80)

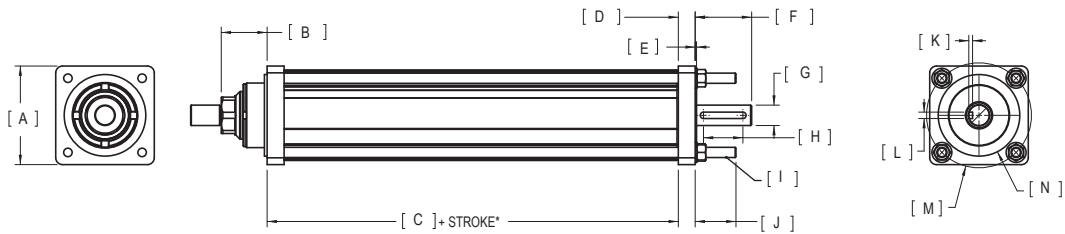

		FT35	FT60	FT80
A	in	□ 3.63	□ 6.38	□ 8.50
	mm	92.1	161.9	215.9
B	in	1.69	2.25	3.03
	mm	42.9	57.1	77.0
C	in	9.1*	15.3	19.8
	mm	232*	389	503
D	in	0.62	0.83	0.90
	mm	15.7	21.1	22.9
E	in	0.05	0.10	0.10
	mm	1.3	2.5	2.5
F	in	2.08	2.41	3.34
	mm	52.8	61.2	84.7
G	in	∅ 0.748 +0.00/-0.0005	∅ 1.378 +0.00/-0.0006	∅ 2.362 +0.00/-0.0005
	mm	19.0 +0.00/-0.013	35.0 +0.00/-0.016	60.0 +0.00/-0.013
H	in	1.45	1.60	1.48
	mm	36.8	40.5	37.5

		FT35	FT60	FT80
I	in	3/8- 16 UNC - 2A	9/16 - 12 UNC - 2A	3/4- 10 UNC - 2A
	mm	M8 x 1.25 6g	M14 x 2.0 6g	M20 x 2.5 6g
J	in	1.50	2.0	2.0
	mm	38.1	50.7	50.7
K	in	0.138 +0.004/-0.00	0.197 +0.008/-0.00	0.278 +0.005/-0.00
	mm	3.5 +0.1 0.0	5.0 +0.2 -0.0	7.0 +0.1 -0.0
L	in	0.236 -0.00/-0.002	0.3937 +0.0006/-0.0020	0.709 -0.001/-0.002
	mm	6.0 -0.012/-0.042	10.0 -0.015/-0.051	18.0 -0.018/-0.061
M	in	∅ 3.860 BC	∅ 6.79 BC	∅ 9.33 BC
	mm	98.0	172.4	237.0
N	in	∅ 3.00	∅ 5.00	∅ 6.75
	mm	76.2	127.0	171.5

\*Add 20 mm if choosing high capacity option for the FT35

### Base Actuator (FT45)

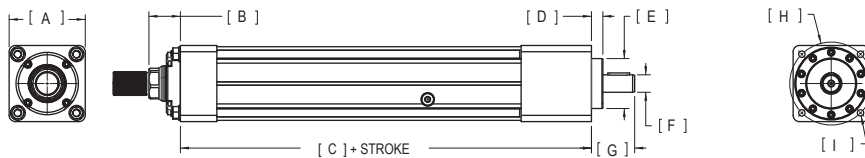

		FT45
A	in	□ 4.80
	mm	122.0
B	in	1.99
	mm	50.5
C	in	13.9
	mm	354
D	in	0.72
	mm	18.3
E	in	∅ 3.15
	mm	80.00

		FT45
F	in	∅ 1.102 +0.00/-0.0005
	mm	28.0 +0.00/-0.013
G	in	2.73
	mm	69.3
H	in	∅ 5.236 BC
	mm	133.0
I	mm	4X M12X1.75 - 6H ↓ 1.0

Pre-sale drawings and models are representative and are subject to change. Certified drawings and models are available for a fee. Consult your local Exlar representative for details.

## Clevis Mount

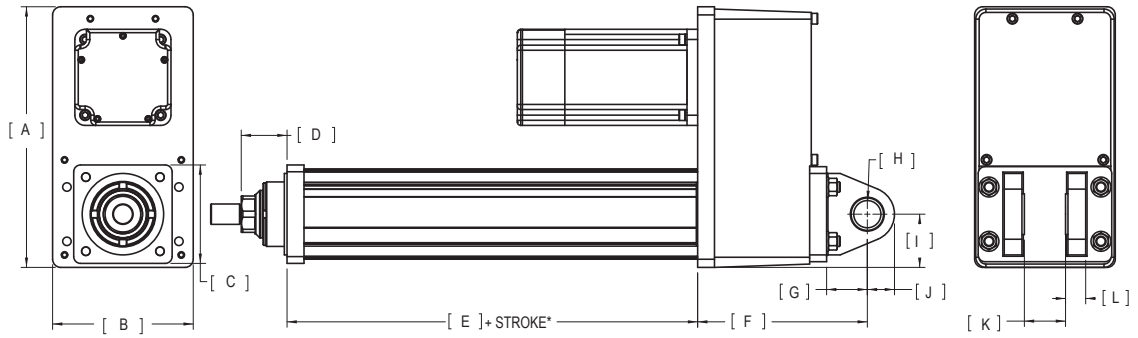

		FT35	FT45 (Option C)	FT45 (Option G)	FT60
A	in	9.60	14.55	14.55	15.55
	mm	243.8	369.5	369.5	395.0
B	in	5.18	7.48	7.48	8.53
	mm	131.6	190.0	190.0	216.7
C	in	□ 3.63	□ 4.80	□ 4.80	□ 6.38
	mm	92.1	122.0	122.0	161.9
D	in	1.69	1.99	1.99	2.25
	mm	42.9	50.5	50.0	57.1
E	in	9.1*	13.9	13.9	15.3
	mm	232*	354	354	368
F	in	6.3	9.0	7.9	9.0
	mm	159	229	201	229
G	in	1.50	2.12	1.26	2.5
	mm	38.1	53.8	32.0	63.5
H	in	∅ 1.000** +0.002 / -0.001	∅ 1.378 ±0.001	∅ 0.787 H9	∅ 1.750*** +0.002 / -0.001
	mm	25.4 +0.05 / -0.03	35.0 ±0.03	20.00 H9	44.45 +0.05 / -0.03
I	in	2.0	3.1	3.1	3.43
	mm	50	78	78	87.1
J	in	1.00	1.4	0.6	2.13
	mm	25.4	35	15	54.0
K	in	0.74	1.0	0.6	2.51
	mm	19	25	15	63.9
L	in	1.52	2.03	1.18	1.25
	mm	38.5	51.6	30.0	31.8

Parallel motor mount shown.

\*Add 20 mm if choosing high capacity option for the FT35.

\*\* If "G" metric clevis option, ∅ 27 mm + 0.00 / - 0.06

\*\*\* If "G" metric clevis option, ∅ 45 mm + 0.00 / - 0.08

# FT Series Linear Actuators

## Front Flange

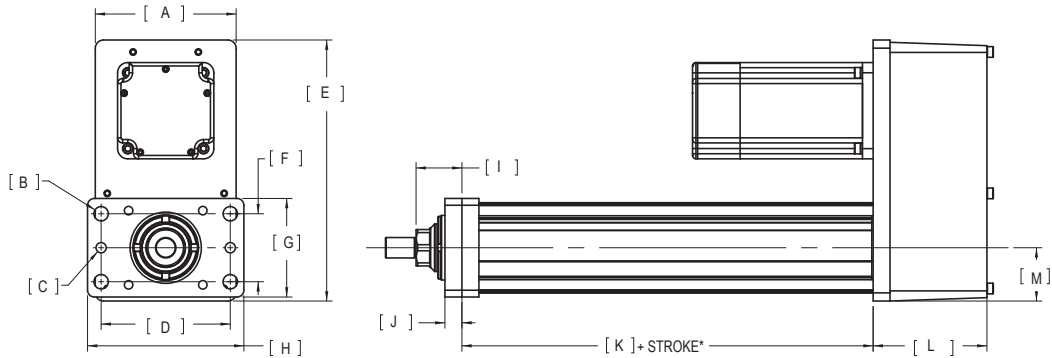

		FT35	FT45	FT60	FT80
A	in	5.18	7.48	6.82	8.77
	mm	131.6	190.0	173.2	222.8
B	in	Ø 0.53	Ø 0.69	Ø 0.66	Ø 0.78
	mm	13.5	17.5	16.7	19.8
C	in	Ø 0.375 +0.001 / -0.000	Ø 0.500 +0.001 / -0.000	Ø 0.501 +0.001 / -0.000	Ø 0.625 +0.001 / -0.000
	mm	9.53 +0.03 / 0.00	12.70 +0.03 / 0.00	12.7 +0.03 / 0.00	15.9 +0.025 / 0.000
D	in	4.75	6.38	8.32	10.75
	mm	120.7	161.9	211.2	273.1
E	in	9.6	14.55	14.32	17.33
	mm	243.8	369.5	363.7	440.2
F	in	2.50	3.82	4.57	6.00
	mm	63.5	97.0	116.2	152.4
G	in	3.63	5.00	6.38	8.50
	mm	92.1	127.0	161.9	215.9
H	in	5.8	7.63	10.00	12.75
	mm	146	193.7	254.0	323.9
I	in	1.69	1.99	2.25	3.03
	mm	42.9	50.5	57.1	77.0
J	in	0.63	1.00	1.00	1.25
	mm	15.9	25.4	25.4	31.8
K	in	9.1*	13.9	15.3	19.8
	mm	232*	354	388	503
L	in	4.19	5.26	4.6	6.43
	mm	106.3	133.7	116	163.3
M	in	1.96	3.05	3.19	4.40
	mm	49.8	77.5	81.0	111.8

\*Add 20 mm if choosing high capacity option for the FT35.

Pre-sale drawings and models are representative and are subject to change. Certified drawings and models are available for a fee. Consult your local Exlar representative for details.



## Rear Flange (FT35, FT60)

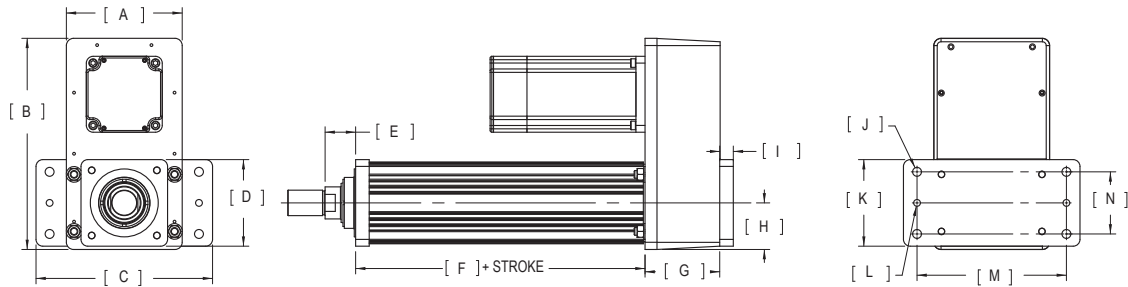

		FT35	FT60
A	in	5.18	8.53
	mm	131.6	216.7
B	in	9.60	15.55
	mm	243.8	395.0
C	in	9.00	13.00
	mm	228.6	330.2
D	in	□ 3.63	□ 6.38
	mm	92.1	161.9
E	in	1.69	2.25
	mm	42.9	57.1
F	in	9.1*	15.3
	mm	232*	388
G	in	4.13	5.50
	mm	104.8	139.7

\*Add 20 mm if choosing high capacity option for the FT35

		FT35	FT60
H	in	1.96	3.43
	mm	49.8	87.1
I	in	0.63	1.00
	mm	15.9	25.4
J	in	Ø 0.53	Ø 0.66
	mm	13.5	16.7
K	in	3.5	6.38
	mm	88.9	161.9
L	in	Ø 0.375 +0.001/-0.000	Ø 0.501 +0.001/-0.000
	mm	Ø 9.53 +0.03/-0.00	12.7 +0.03/0.00
M	in	6.5	11.00
	mm	165.1	279.4
N	in	2.50	4.58
	mm	63.5	116.2

## Rear Flange (FT45)

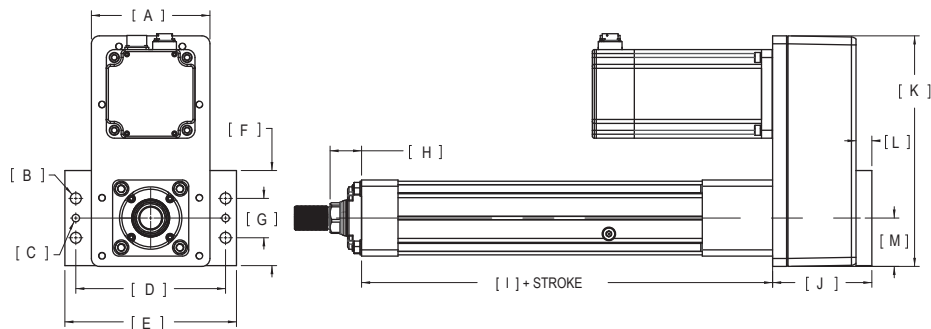

	A	B	C	D	E	F	G
in	7.48	Ø 0.69	Ø 0.472 +0.001/-0.00	9.45	10.83	6.00	2.48
mm	190.0	17.5	12.00 +0.03/0.00	240.0	275.0	152.4	63.1

	H	I	J	K	L	M
in	1.99	13.9	6.26	14.55	1.00	3.05
mm	50.5	354	159.0	369.5	25.4	77.5

Pre-sale drawings and models are representative and are subject to change. Certified drawings and models are available for a fee. Consult your local Exlar representative for details.

# FT Series Linear Actuators

## Trunnion Mount (FT35, FT60)

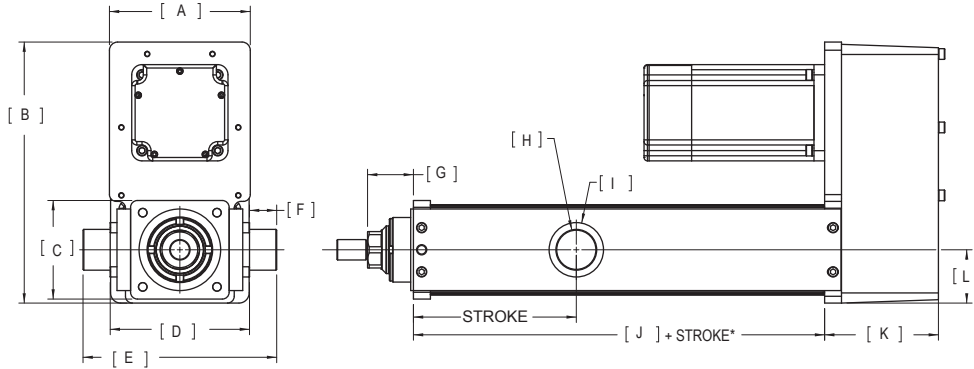

		FT35	FT60
A	in	5.18	6.82
	mm	131.6	173.2
B	in	9.60	14.32
	mm	243.8	363.7
C	in	□ 3.63	□ 6.38
	mm	92.1	161.9
D	in	5.12	8.13
	mm	130.1	206.4
E	in	7.12	12.13
	mm	180.9	308.0
F	in	1.00	2.00
	mm	25.4	50.8

		FT35	FT60
G	in	1.69	2.25
	mm	42.9	57.1
H	in	∅ 1.500** ±0.001	∅ 2.500*** ±0.001
	mm	38.1 ±0.03	63.50 ±0.03
I	in	∅ 2.00	∅ 3.50
	mm	50.8	88.9
J	in	9.1*	15.3
	mm	232*	388
K	in	4.19	4.57
	mm	106.3	116.1
L	in	1.96	3.19
	mm	49.8	81.0

\*Add 20 mm if choosing high capacity option. for the FT35.

\*\* If "Q" metric side trunnion option, ∅ 35 mm h7

\*\*\* If "Q" metric side trunnion option, ∅ 60 mm h9

## Trunnion Mount (FT45)

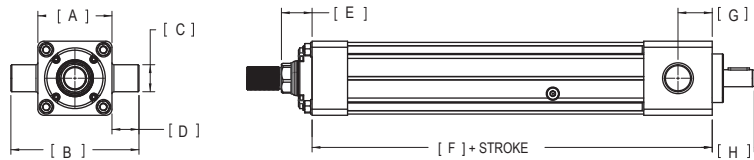

		Imperial (A or 2)	Metric (V or P)
A	in	□ 4.80	□ 4.80
	mm	122.0	122.0
B	in	8.30	7.95
	mm	210.9	202.0
C	in	∅ 1.750 +0.000/-0.002	∅ 1.969 +0.000/-0.002
	mm	44.45 0.00/-0.05	50.00 0.00/-0.05
D	in	1.75	1.57
	mm	44.5	40.00

		Imperial (A or 2)	Metric (V or P)
E	in	1.99	1.99
	mm	50.5	50.5
F	in	13.9	13.9
	mm	354	354
G	in	2.22	2.22
	mm	56.4	56.4
H	in	2.73	2.73
	mm	69.3	69.3

Pre-sale drawings and models are representative and are subject to change. Certified drawings and models are available for a fee. Consult your local Exlar representative for details.

## Extended Tie Rod Mount (FT35, FT60, FT80)

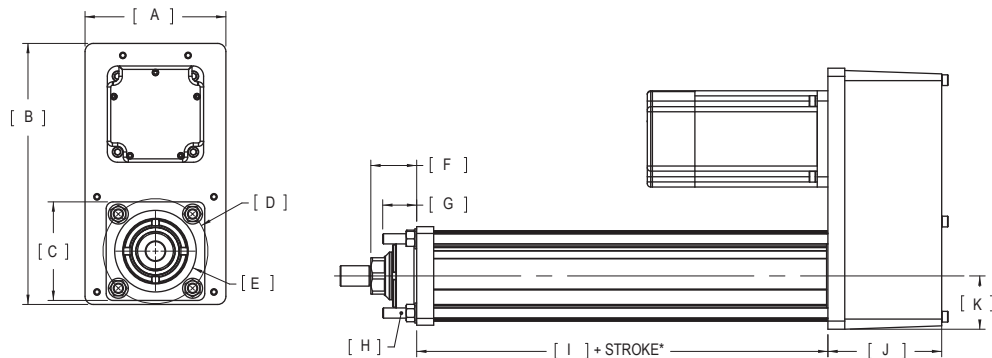

		FT35	FT60	FT80
A	in	5.18	6.82	8.77
	mm	131.6	173.2	222.8
B	in	9.60	14.32	17.33
	mm	243.8	363.7	440.2
C	in	□ 3.63	□ 6.38	□ 8.50
	mm	92.1	161.9	215.9
D	in	∅ 3.86 BC	∅ 6.79 BC	∅ 9.33 BC
	mm	98.0	172.4	237.0
E	in	∅ 3.000 +0.000/-0.002	∅ 5.000 +0.000/-0.002	∅ 6.75 +0.000/-0.002
	mm	76.20 0.00/-0.05	127.0 0.00/-0.05	171.45 0.00/-0.05
F	in	1.69	2.25	3.03
	mm	42.9	57.1	77.0

		FT35	FT60	FT80
G	in	1.25	2.00	3.50
	mm	31.8	50.8	88.9
H	in	3/8-16 UNC-2A	9/16-12 UNC-2A	3/4-10 UNC-2A
	mm	M8 x 1.25 6g	M14 x 2.0 6g	M20 x 2.5 6g
I	in	9.1*	15.3	19.8
	mm	232*	388	503
J	in	4.19	4.57	6.43
	mm	106.3	116.1	163.3
K	in	1.96	3.19	4.40
	mm	49.8	81.0	111.8

\*Add 20 mm if choosing high capacity option for the FT35

## Extended Tie Rod Mount (FT45)

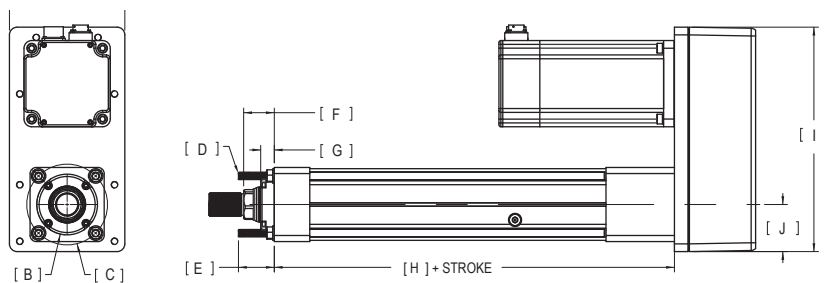

	A	B	C	D	E
in	7.48	∅ 3.937	∅ 5.236 BC	1/2-13 UNC	2.3
mm	190.0	100.00	133.00	M12 x 1.75 6g	59

	F	G	H	I	J
in	1.99	0.88	13.9	14.55	3.05
mm	50.5	22.4	354	369.5	77.5

Pre-sale drawings and models are representative and are subject to change. Certified drawings and models are available for a fee. Consult your local Exlar representative for details.

# FT Series Linear Actuators

## Side Lug Mount (FT35, FT60, FT80)

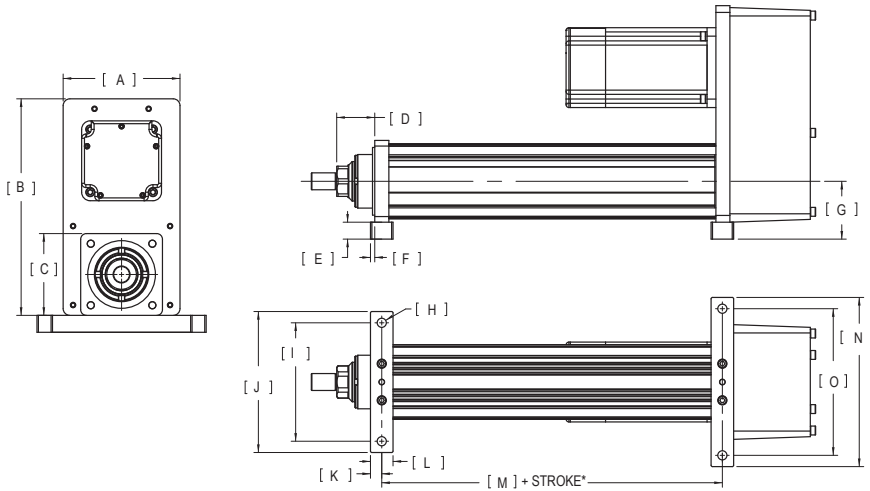

		FT35	FT60	FT80
A	in	5.18	6.82	8.77
	mm	131.6	173.2	222.8
B	in	9.60	14.32	17.33
	mm	243.8	363.7	440.2
C	in	□ 3.63	□ 6.38	□ 8.50
	mm	92.1	161.9	215.9
D	in	1.69	2.25	3.03
	mm	42.9	57.1	77.0
E	in	0.75	1.0	2.00
	mm	19.1	25.4	50.8
F	in	0.19	0.50	0.50
	mm	4.8	12.7	12.7
G	in	2.56	4.19	6.25
	mm	65.1	106.4	158.75

		FT35	FT60	FT80
H	in	∅ 0.41	∅ 0.53	∅ 0.78
	mm	10.3	13.5	19.8
I	in	5.25	8.50	12.75
	mm	133.4	215.9	323.9
J	in	6.25	10.00	10.75
	mm	158.8	254.0	273.1
K	in	0.50	1.00	1.25
	mm	12.7	25.4	31.8
L	in	1.00	2.00	2.50
	mm	25.4	50.8	63.5
M	in	9.1*	15.3	19.6
	mm	232*	388	498
N	in	7.50	10.00	12.75
	mm	190.5	254.0	323.9
O	in	6.5	8.50	10.75
	mm	165.1	215.9	273.1

\*Add 20 mm if choosing high capacity option for the FT35.

Pre-sale drawings and models are representative and are subject to change. Certified drawings and models are available for a fee. Consult your local Exlar representative for details.

## Side Lug Mount (FT45)

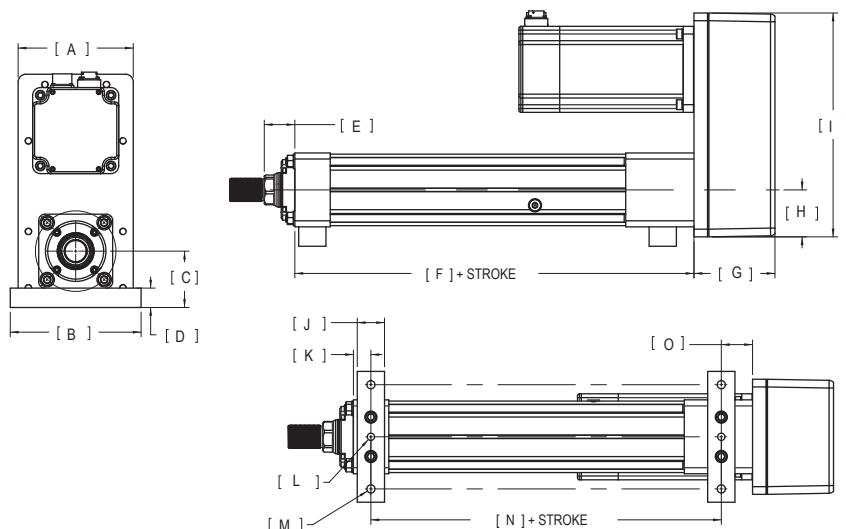

		FT45	
A	in	7.48	
	mm	190.0	
B	in	8.50	
	mm	215.9	
C	in	3.66	
	mm	93.0	
D	in	1.26	
	mm	32.0	
E	in	1.99	
	mm	50.5	
F	in	13.9	
	mm	354	
G	in	5.26	
	mm	133.6	

		FT45	
H	in	3.05	
	mm	77.5	
I	in	14.55	
	mm	369.5	
J	in	1.77	
	mm	45.0	
K	in	1.15	
	mm	29.2	
L	in	Ø 0.472 +0.001/0.000	
	mm	12.0 +0.03/0.00	
M	in	Ø 0.53	
	mm	13.5	
N	in	10.57	
	mm	269.4	
O	in	2.22	
	mm	56.4	

Pre-sale drawings and models are representative and are subject to change. Certified drawings and models are available for a fee. Consult your local Exlar representative for details.

# FT Series Linear Actuators

## Side Mount

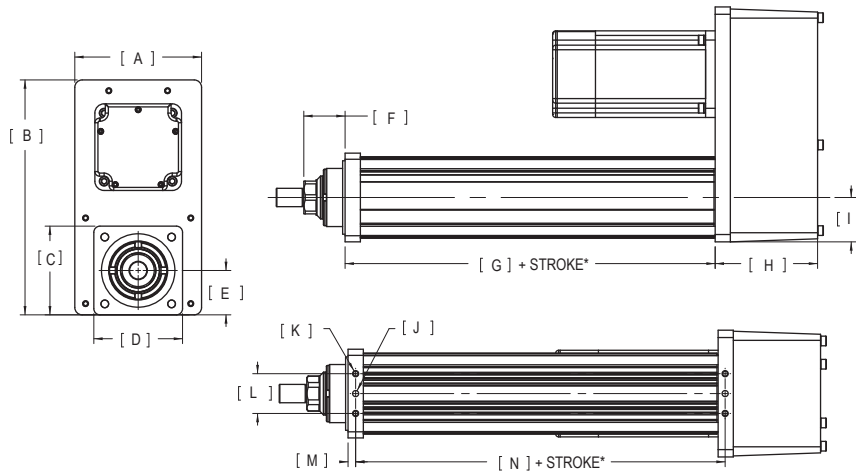

\*Add 20 mm if choosing high capacity option.

		FT35	FT60	FT80
A	in	5.18	6.82	8.77
	mm	131.6	173.2	222.8
B	in	9.60	14.32	17.38
	mm	243.8	363.7	440.2
C	in	□ 3.63	□ 6.38	□ 8.50
	mm	92.1	161.9	215.9
D	in	□ 3.63	□ 6.38	□ 8.50
	mm	92.1	161.9	215.9
E	in	1.81	NA	NA
	mm	46.0	NA	NA
F	in	1.69	2.25	3.03
	mm	42.9	57.1	77.0
G	in	9.1*	15.3	19.8
	mm	232*	388	503

		FT35	FT60	FT80
H	in	4.19	4.57	6.43
	mm	106.3	116.1	163.5
I	in	1.81	3.19	4.25
	mm	46.1	81.0	108.0
J		Ø 0.2500 <sub>↓</sub> 0.400 <sup>1</sup> +0.0000/ -0.0005	Ø 0.5000 <sub>↓</sub> 1.00 <sup>2</sup> +0.0000/ -0.0005	Ø 0.6250 <sub>↓</sub> 1.375 <sup>3</sup> +0.0000/ -0.0005
		1/4-20 UNC- 2B ↓ .63 <sup>1</sup>	1/2-13 UNC-2B ↓ 1.13 <sup>2</sup>	5/8-11 UNC- 2B ↓ 1.25 <sup>3</sup>
L	in	1.63	2.50	4.00
	mm	41.3	63.5	101.6
M	in	0.31	0.50	0.75
	mm	8	12.7	19.1
N	in	9.1*	15.3	19.6
	mm	232*	388	498

\*Add 20 mm if choosing high capacity option for the FT35.

<sup>1</sup> If "J" or "K" metric side mount options, M6 x 1.0 ↓ 9 mm with Ø 6 mm M7 ↓ 9 mm dowel hole

<sup>2</sup> If "J" or "K" metric side mount options, M12 x 1.75 ↓ 19 mm with Ø 12 mm M7 ↓ 12 mm Dowel Hole

<sup>3</sup> If "J" or "K" metric side mount options, M16 x 2.0 ↓ 16 mm with Ø 12 mm M7 ↓ 12 mm dowel hole

## Rear Eye Mount

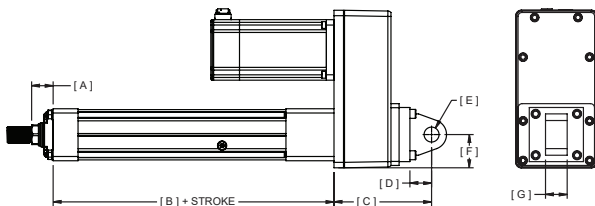

		FT45 (Option Y)	FT45 (Option W)
A	in (mm)	1.99 (50.5)	1.99 (50.5)
B	in (mm)	13.9 (354)	13.9 (354)
C	in (mm)	9.01 (228.9)	7.90 (200.7)
D	in (mm)	2.00 (50.8)	1.26 (32.0)
E	in (mm)	1.378 ± 0.001 (35.0 ± 0.03)	0.787 H9 (20.00 H9)
F	in (mm)	3.07 (77.9)	3.07 (77.9)
G	in (mm)	2.00 (50.8)	1.18 (30.0)

Pre-sale drawings and models are representative and are subject to change. Certified drawings and models are available for a fee. Consult your local Exlar representative for details.

## Rod Ends

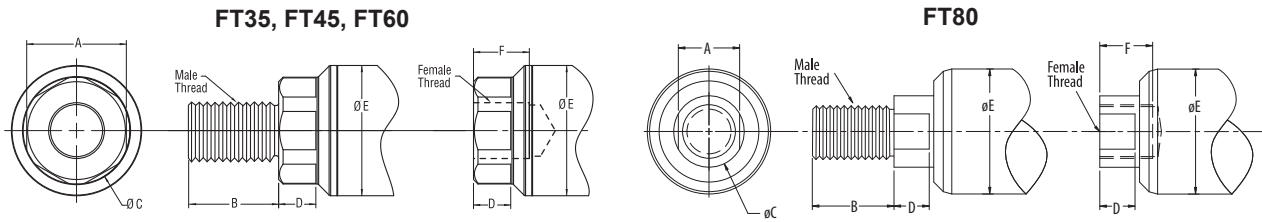

	A	B	ØC	D	ØE	F	Male U.S.	Male Metric	Female U.S.	Female Metric
FT35	1.34 (34)	1.125 (28.6)	1.434 (36.4)	0.50 (12.7)	1.750 (44.5)	0.750 (19.1)	3/4-16 UNF-2A	M16x1.5 6g	3/4-16 UNF-2B	M16x1.5 6h
FT45	1.81 (46.0)	2.25 (57.2)	2.0 (50.8)	0.63 (15.9)	2.250 (57.2)	1.50 (38.1)	1 1/2-12 UN-2A	M36x3 6g	1 1/2-12 UN-2B	M36x3 6h
FT60	2.36 (60.0)	2.750 (69.9)	2.360 (59.9)	0.750 (19.1)	3.000 (76.2)	2.000 (50.8)	1 7/8-12 UN-2A	M42x4.5 6g	1 7/8-12 UN-2B	M42x4.5 6h

	A	B	ØC	D	ØE	F	Male U.S.	Male Metric	Female U.S.	Female Metric
FT80	2.75 (69.9)	4.019 (102.1)	3.143 (79.8)	1.000 (25.4)	4.000 (101.6)	2.250 (57.2)	2 1/2-12 UN-2A	M56x5.5 6g	2 1/2-12 UN-2B	M56x5.5 6h

Dimensions shown in inches (mm)

## Case Dimensions

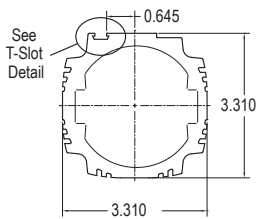

FT35

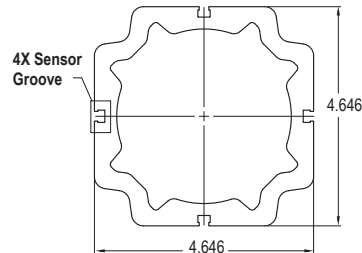

FT45

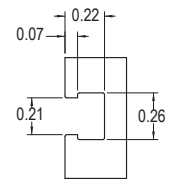

Detail 4X Sensor Groove

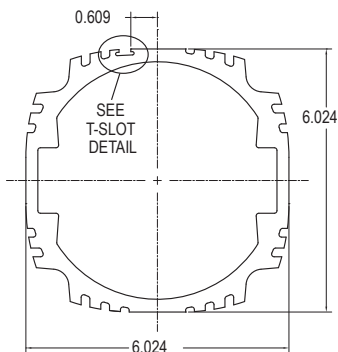

FT60

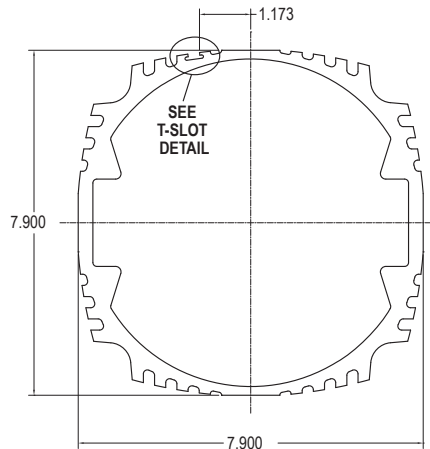

FT80

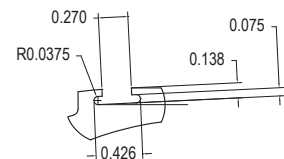

T-Slot Detail

Pre-sale drawings and models are representative and are subject to change. Certified drawings and models are available for a fee. Consult your local Exlar representative for details.



# FT Series Linear Actuators

## Motor Mount Drawing

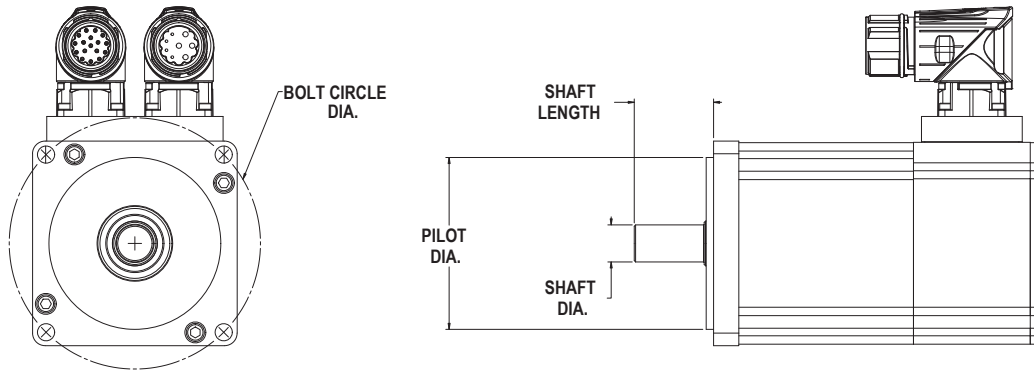

## FT35 Motor Mount Codes

Bolt Circle Diameter (mm)	Pilot Diameter (mm)	Shaft Diameter (mm)	Shaft Length (mm)	Key Width (mm)	Motor Mount Code
68	60	12	30	4	GFB
68	60	16	48	5	GFA
70	50	14	30	5	JGA
70	50	16	30	5	GGB
70	50	16	36	5	EGB
70	50	16	40	5	GGA
75	60	14	30	5	IHB
75	60	16	32	5	GHB
75	60	16	48	5	GHA
85	70	16	37	5	GIB
85	70	22	56	6	GIA
90	60	19	40	6	JKF
90	70	14	30	5	JKD
90	70	16	35	NA	JKC
90	70	16	40	5	JKG
90	70	19	40	6	JKA
95	50	14	30	5	ELC
95	65	14	30	5	ELA
95	65	16	30	5	ELB
100	50	16	31	6	GMC
100	80	14	30	5	IMA
100	80	14	40	5	JMC
100	80	16	40	5	IMB
100	80	19	40	6	IMC
100	80	19	55	6	JMD
100	80	20	40	6	GMB
100	80	22	48	6	GMA
115	95	19	40	6	INA
115	95	19	55	6	JNC

Bolt Circle Diameter (mm)	Pilot Diameter (mm)	Shaft Diameter (mm)	Shaft Length (mm)	Key Width (mm)	Motor Mount Code
115	95	22	45	8	JND
115	95	22	70	NA	JNB
115	95	24	45	8	JNA
115	95	24	50	8	INB
120	60	22	39	6	G7C
120	90	22	46	6	G7B
130	95	19	40	6	IPC
130	95	24	50	8	IPD
130	110	19	40	6	IPA
130	110	24	50	8	IPB
140	110	32	64	10	E5A
145	110	19	40	6	JQJ
145	110	19	55	5	JQG
145	110	19	55	6	JQK
145	110	22	55	8	JQH
145	110	22	55	6	JQF
145	110	22	70	8	JQE
145	110	24	55	8	JQD
145	110	24	65	8	JQC
145	110	28	55	8	JQB
145	110	28	63	8	JQA
165	95	24	50	8	IRG
165	110	24	50	8	IRF
165	130	24	50	8	IRA
165	130	28	60	8	IRB
165	130	32	50	10	IRD
165	130	32	58	10	IRC
165	130	32	80	10	IRE
165	130	32	80	10	IRE

## FT45 Motor Mount Codes

Bolt Circle Diameter (mm)	Pilot Diameter (mm)	Shaft Diameter (mm)	Shaft Length (mm)	Key Width (mm)	Motor Mount Code
85	70	22	49	6	GIA
95	65	16	30	5	ELB
100	50	16	31	6	GMC
100	80	14	30	5	IMA
100	80	14	40	5	JMC
100	80	16	40	5	IMB
100	80	19	40	6	IMC
100	80	19	55	6	JMD
100	80	20	40	6	GMB
100	80	22	52	6	GMA
115	95	19	40	6	INA
115	95	19	55	6	JNC
115	95	22	45	8	JND
115	95	22	70	NA	JNB
115	95	24	45	8	JNA
115	95	24	50	8	INB
120	60	22	39	6	G7C
120	90	22	46	6	G7B
120	90	32	88	10	G7A
120	100	32	85	10	G7D
130	95	19	40	6	IPC
130	95	24	50	8	IPD
130	110	19	40	6	IPA
130	110	24	50	8	IPB
140	110	32	64	10	E5A
145	110	19	55	5	JQG
145	110	19	55	6	JQK
145	110	22	55	8	JQH

Bolt Circle Diameter (mm)	Pilot Diameter (mm)	Shaft Diameter (mm)	Shaft Length (mm)	Key Width (mm)	Motor Mount Code
145	110	22	55	6	JQF
145	110	22	70	8	JQE
145	110	24	58	8	JQD
145	110	24	65	8	JQC
145	110	28	55	8	JQB
145	110	28	63	8	JQA
165	95	24	50	8	IRG
165	110	24	50	8	IRF
165	130	24	50	8	IRA
165	130	28	60	8	IRB
165	130	32	50	10	IRD
165	130	32	58	10	IRC
165	130	32	80	10	IRE
190	155	32	60	10	I2A
200	114.3	22	55	6	JSE
200	114.3	28	55	8	JSF
200	114.3	35	70	10	JSB
200	114.3	35	79	10	JSA
200	114.3	42	113	10	JSD
200	114.3	42	113	NA	JSG
215	130	32	60	10	ITE
215	180	24	50	10	ITA
215	180	28	60	10	ITB
215	180	32	58	10	ITC
215	180	32	80	10	ITD
215	180	38	80	10	ITF
215	180	42	82	12	ITG
215	180	42	82	12	ITG

## FT60 Motor Mount Codes

Bolt Circle Diameter (mm)	Pilot Diameter (mm)	Shaft Diameter (mm)	Shaft Length (mm)	Key Width (mm)	Motor Mount Code
100	50	16	31	6	GMC
100	80	20	40	6	GMB
100	80	22	48	6	GMA
115	95	19	40	6	INA
115	95	19	55	6	JNC
115	95	22	45	8	JND
115	95	22	70	NA	JNB
115	95	24	45	8	JNA
115	95	24	50	8	INB
120	60	22	39	6	G7C
120	90	22	46	6	G7B
120	90	32	88	10	G7A
120	100	32	85	10	G7D
120	130	40	112	12	G7E
130	95	19	40	6	IPC
130	95	24	50	8	IPD
130	110	19	40	6	IPA
130	110	24	50	8	GPC
130	110	24	50	8	IPB
130	110	25	55	8	GPB
130	110	32	65	10	GPA
140	110	32	64	10	E5A
145	110	19	55	5	JQG
145	110	19	55	6	JQK
145	110	22	55	8	JQH
145	110	22	55	6	JQF
145	110	22	70	8	JQE
145	110	24	58	8	JQD
145	110	24	65	8	JQC

Bolt Circle Diameter (mm)	Pilot Diameter (mm)	Shaft Diameter (mm)	Shaft Length (mm)	Key Width (mm)	Motor Mount Code
145	110	28	55	8	JQB
145	110	28	63	8	JQA
165	80	32	63	10	GRE
165	95	24	50	8	IRG
165	110	24	50	8	IRF
165	130	24	50	8	IRA
165	130	28	60	8	IRB
165	130	32	50	10	IRD
165	130	32	58	10	IRC
165	130	32	72	10	GRD
165	130	32	80	10	IRE
165	130	40	80	12	GRB
165	130	40	97	12	GRC
165	130	40	112	12	GRA
190	155	32	60	10	I2A
200	114.3	22	55	6	JSE
200	114.3	28	55	8	JSF
200	114.3	35	70	10	JSB
200	114.3	35	80	10	JSA
200	114.3	42	113	10	JSD
200	114.3	42	113	12	JSG
215	130	32	60	10	ITE
215	180	24	50	10	ITA
215	180	28	60	10	ITB
215	180	32	58	10	ITC
215	180	32	80	10	ITD
215	180	38	80	10	ITF
215	180	42	85	12	ITG

## FT80 Motor Mount Codes

Bolt Circle Diameter (mm)	Pilot Diameter (mm)	Shaft Diameter (mm)	Shaft Length (mm)	Key Width (mm)	Motor Mount Code
130	110	24	50	8	GPC
130	110	25	55	8	GPB
130	110	32	72	10	GPA
165	80	32	63	10	GRE
165	95	24	50	8	IRG
165	110	24	50	8	IRF
165	130	24	50	8	IRA
165	130	28	60	8	IRB
165	130	32	50	10	IRD
165	130	32	58	10	IRC
165	130	32	72	10	GRD
165	130	32	80	10	IRE
165	130	40	80	12	GRB
165	130	40	102	12	GRC
165	130	40	112	12	GRA
190	155	32	60	10	I2A
200	114.3	28	55	8	JSF
200	114.3	35	70	10	JSB
200	114.3	35	80	10	JSA
200	114.3	42	113	10	JSD
200	114.3	42	113	12	JSG
215	130	32	60	10	ITE

Bolt Circle Diameter (mm)	Pilot Diameter (mm)	Shaft Diameter (mm)	Shaft Length (mm)	Key Width (mm)	Motor Mount Code
215	160	40	100	12	GTC
215	160	55	112	16	GTA
215	180	24	50	10	ITA
215	180	28	58	10	ITB
215	180	32	58	10	ITC
215	180	32	80	10	ITD
215	180	38	80	10	ITF
215	180	42	82	12	ITG
235	200	35	70	10	JUC
235	200	42	85	12	JUB
235	200	42	116	12	JUD
235	200	55	116	16	JUA
265	230	38	80	10	IVA
265	230	38	110	10	IVB
265	230	42	110	12	IVC
265	230	55	110	16	JVA
265	230	60	140	18	JVC
265	230	65	140	18	JVB
300	250	48	82	14	IWB
300	250	48	112	14	IWA
300	250	60	140	18	JWA

# FT Series Ordering Guide

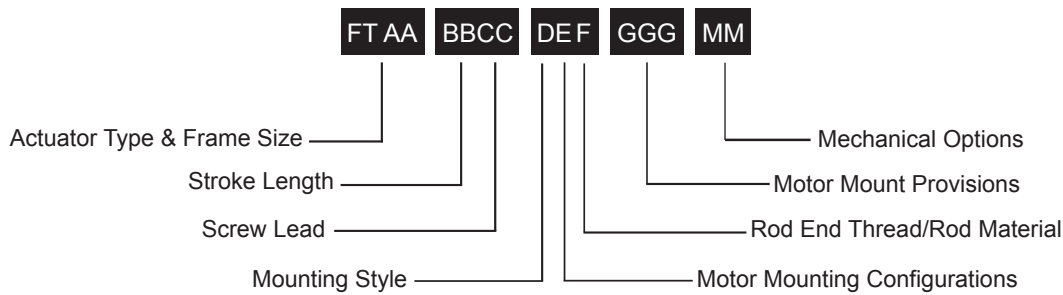

## AA = FT Frame Size

35 = 3.5 inch (90 mm)  
 45 = 4.7 inch (120 mm)  
 60 = 5.9 inch (150 mm)  
 80 = 7.9 inch (200 mm)

## BB = Stroke Length

06 = 6 inch (152 mm) FT35, FT45  
 12 = 12 inch (305 mm) FT35, 45, 60, 80  
 18 = 18 inch (457 mm) FT35, 45  
 24 = 24 inch (610 mm) FT35, 45, 60, 80  
 36 = 36 inch (914 mm) FT35, 45, 60, 80  
 48 = 48 inch (1219 mm) FT35, 45, 60, 80

## CC = Screw Lead

05 = 0.2 inch, FT35, 45  
 06 = 0.23 inch, FT60, 80  
 10 = 0.39 inch, FT35, 45  
 12 = 0.47 inch, FT60, 80  
 20 = 0.79 inch, FT35  
 30 = 1.18 inch, FT60, 80

## D = Mounting Style <sup>1</sup>

N = None  
 F = Front flange, English  
 Z = Front flange, Metric, FT45  
 R = Rear flange, English <sup>4,5</sup>  
 C = Rear clevis, English <sup>4,5</sup>  
 G = Rear clevis, Metric <sup>4,5</sup>  
 Y = Rear eye, English <sup>4</sup>, FT45  
 W = Rear eye, Metric <sup>4</sup>, FT45  
 L = Side lugs  
 S = Side mount, English FT35, 60, 80  
 J = Side mount, Metric FT35, 60, 80  
 T = Side trunnion mount, English <sup>5,6</sup> FT35, 60, 80  
 Q = Side trunnion mount, Metric <sup>5,6</sup> FT35, 60, 80  
 2 = Rear trunnion mount, English, FT45  
 P = Rear trunnion mount, Metric, FT45  
 E = Extended tie rods, English  
 M = Extended tie rods, Metric

## E = Motor Mounting Configurations <sup>3</sup>

N = None  
 I = Inline direct drive (includes Exlar standard coupling)  
 P = Parallel, 1:1 belt reduction  
 Q = Parallel, 2:1 belt reduction

## F = Rod End

M = Male, US standard thread  
 A = Male, metric thread  
 F = Female, US standard thread  
 B = Female, metric thread

## GGG = Motor Mount Provisions <sup>3,4</sup>

See page 114-117 for Motor Mount Code.

## MM = Mechanical Options <sup>2</sup>

XT = High capacity roller screw

## Limit Switches

See Page 100 for Limit Switch details

Please provide a 3D CAD Model of motor dimensions with all orders to insure proper mounting compatibility.



For options or specials not listed above or for extended temperature operation, please contact Exlar

### NOTES:

1. Mounting face size, shaft length and other details of particular motors may require special adapters or provisions for mounting. Always discuss your motor selection with your local sales representative.
2. For extended temperature operation consult factory for model number.
3. MAX Std. motor size: FT35: 5.6 inch/165 mm, FT45: 7.1 inch/215 mm, FT60: 7.9 inch/215 mm, FT80: 8.5 inch/300 mm  
 For oversized motors, contact your local sales representative.
4. Not available with inline motor mount, contact your local sales representative.
5. Application details must be approved for use with an FT80.
6. IP65 environmental sealing option not available.

Contact your local sales representative regarding all special actuator components.