

**CURTISS -  
WRIGHT**

**GTW Series Product Catalog**

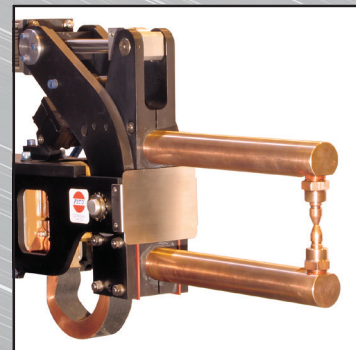
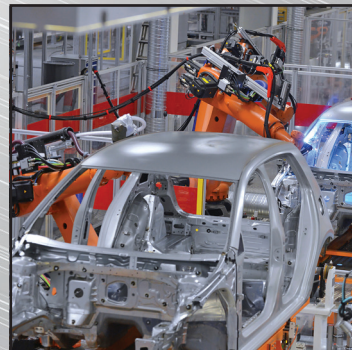
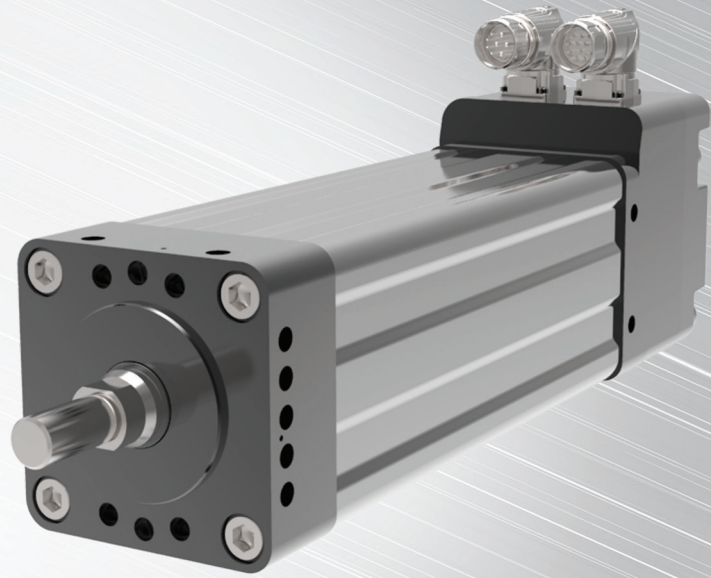

June 2, 2022

**EXLAR<sup>®</sup>**

**Power | Precision | Proven**

# GTW Series

## Product Description

The GTW Series weld-gun focused actuators offer flexible solutions coupled with low maintenance features and proven life reliability. Integrating unique inverted roller screw and T-LAM brushless servo motor technologies the GTW motor / actuator delivers the programmability and precision of electronics combined with high-power density and rugged durability. The GTW weld-gun actuator mirrors the performance of Curtiss-Wright's Exlar GTX product platform and incorporates feature rich designs to serve leading global manufacturers in the automotive weld-gun industry.

Product Basics					
Model	Frame Size mm (in)	Nominal Stroke mm (in)	Peak Force N (lbf)	Continuous Force N (lbf)	Max Speed mm/sec (in/sec)
GTW080	80 (3.15)	150-300 (6-12)	16,730 (3,762)	8,365 (1,881)	1,270 (50)
GTW100	100 (3.94)	150-300 (6-12)	30,784 (6,920)	15,392 (3,460)	953 (37.5)
IP Rating	IP66S				

## Minimize Maintenance / Maximize Life

GTW Series actuators provide benefits where contaminants are present in resistance spot welding applications. The premium seal and wiper design prevents contaminants from infiltrating the mechanical and electrical components of the motor. This unique design minimizes maintenance downtime and maximizes life efficiency of the inverted roller screw components over the millions of duty cycles that are required for productivity outputs.

Operating Conditions and Usage		
<b>Accuracy:</b>		
Screw Lead Error	µm / 300 mm	25
	in/ft	0.001
Screw Travel Variation	µm / 300 mm	30
	in/ft	0.0012
Standard Ambient Temperature	°C	0 to 65
	°F	32 to 149
Friction Torque (typical)	(Nm)	080 (0.23)
		100 (0.34)
IP Rating	IP66S	

Agency Standards & Approvals		
UL		UL 1004-1
		UL 1004-6
CSA		CSA C22.2 NO. 100
CE	EMC	EN 55014-1
		EN 55014-2
	Safety	IEC/EN 60034-1
	RoHS	RoHS 2011/65/EU and amended with directive 2015/863

## Exlar Actuation GTW Solutions

### Improves Throughput and Efficiencies

- Over 20 million welds\*
- Long-life of actuators translates to less downtime
- Force repeatability of ± 50 N, improving quality resulting in less scrap and less destructive tests
- High speed actuator resulting in over 25 welds per minute\*

\*Under typical welding conditions

## Seamless Integration & Compatibility

- Connectorization to match amplifier specification, including interfacing with leading industrial robots enabling quick and easy hookup
  - KUKA, ABB, Comau, and Fanuc robot controllers as well as Bosch Rexroth and Festo 7th axis drive controllers.
- Built-in mounting features for adaption to a variety of weld-gun configurations.
- Integrates with C-Gun, X-Gun, and Pinch systems
- Modular design allows for ease of bolt-on in-field customization

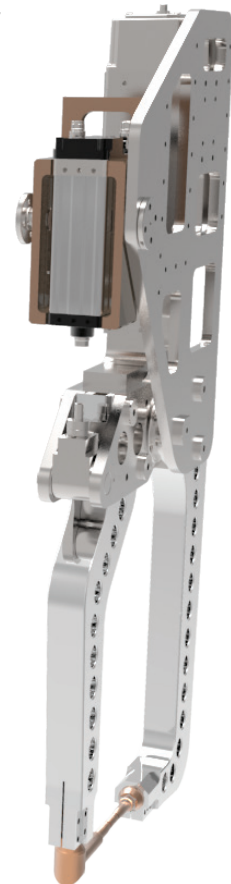

# Product Features

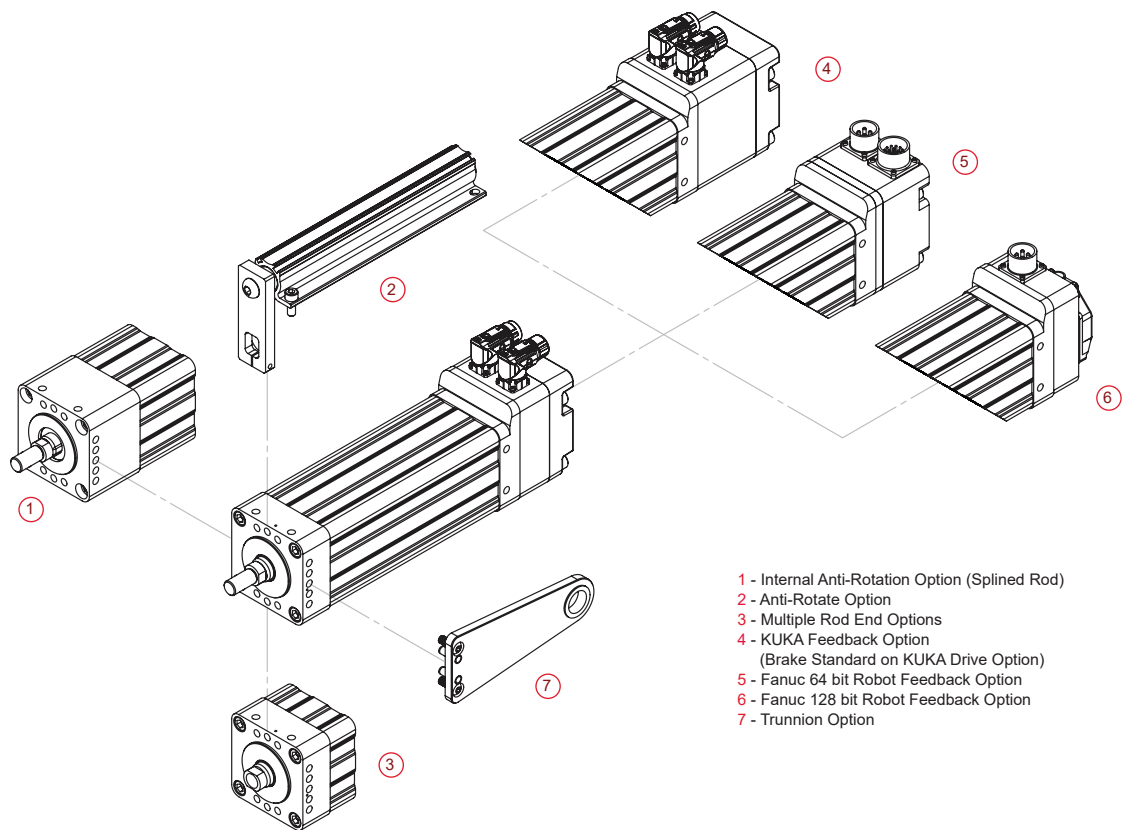
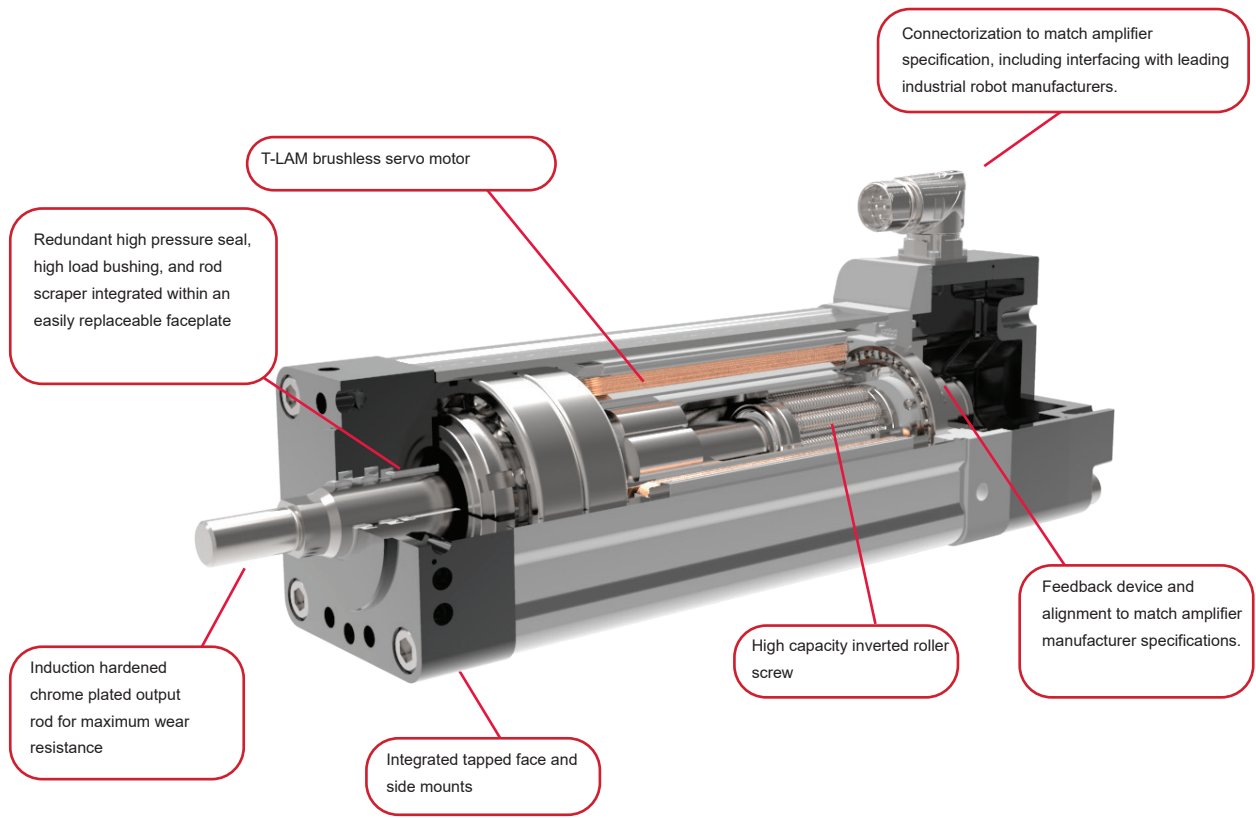

# Mechanical Specifications

Model Code	Nominal Stroke Length mm (in)*	Screw Lead mm (in)	Peak Force Rating N (lbf)	Continuous Force Rating N (lbf)	Max Velocity mm/s (in/s)	Dynamic Load Rating N (lbf)	Armature Inertia kg-m <sup>2</sup> (in-lb-s <sup>2</sup> )
GTW080-150-01	150 (5.9)	2.54 (0.1)	16,730 (3,762)	8,365 (1,881)	254 (10.0)	24,535 (5,516)	0.000369 (0.003267)
GTW080-150-02	150 (5.9)	5.08 (0.2)	9,480 (2,132)	4,740 (1,066)	508 (20.0)	25,798 (5,800)	
GTW080-150-05	150 (5.9)	12.7 (0.5)	4,016 (902)	2,008 (451)	1,270 (50.0)	21,795 (4,900)	
GTW080-300-01	300 (11.8)	2.54 (0.1)	16,730 (3,762)	8,365 (1,881)	254 (10.0)	24,535 (5,516)	0.000455 (0.004029)
GTW080-300-02	300 (11.8)	5.08 (0.2)	9,480 (2,132)	4,740 (1,066)	508 (20.0)	25,798 (5,800)	
GTW080-300-05	300 (11.8)	12.7 (0.5)	4,016 (902)	2,008 (451)	1,270 (50.0)	21,795 (4,900)	
GTW100-150-01	150 (5.9)	2.54 (0.1)	30,784 (6,920)	15,392 (3,460)	191 (7.5)	54,557 (12,266)	0.0014085 (0.012467)
GTW100-150-02	150 (5.9)	5.08 (0.2)	24,196 (5,440)	12,098 (2,720)	381 (15.0)	55,972 (12,584)	
GTW100-150-05	150 (5.9)	12.7 (0.5)	10,888 (2,448)	5,444 (1,224)	953 (37.5)	37,141 (8,350)	
GTW100-300-01	300 (11.8)	2.54 (0.1)	30,784 (6,920)	15,392 (3,460)	191 (7.5)	54,557 (12,266)	0.0017399 (0.015399)
GTW100-300-02	300 (11.8)	5.08 (0.2)	24,196 (5,440)	12,098 (2,720)	381 (15.0)	55,972 (12,584)	
GTW100-300-05	300 (11.8)	12.7 (0.5)	10,888 (2,448)	5,444 (1,224)	953 (37.5)	37,141 (8,350)	

\*Full end to end stroke is 10 mm greater than nominal  
 Maximum velocities listed at maximum voltage (460 VAC) See Speed Force charts for speeds at various voltage levels  
 Continuous force rating based upon 25°C operation

## Estimated Life in Number of Welds

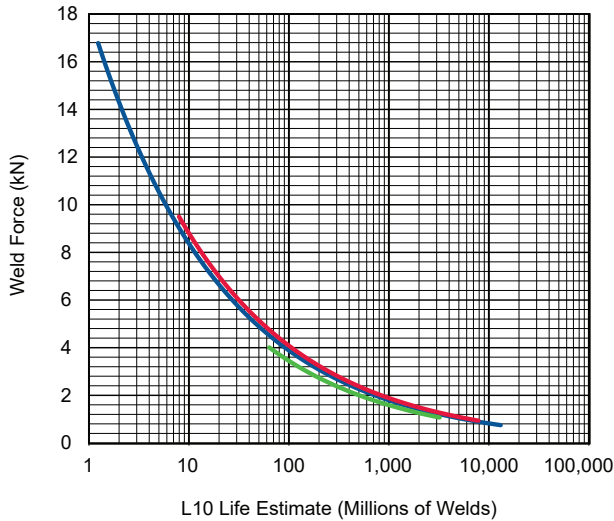

— GTW080-0.1 inch Lead  
 — GTW080-0.2 inch Lead  
 — GTW080-0.5 inch Lead

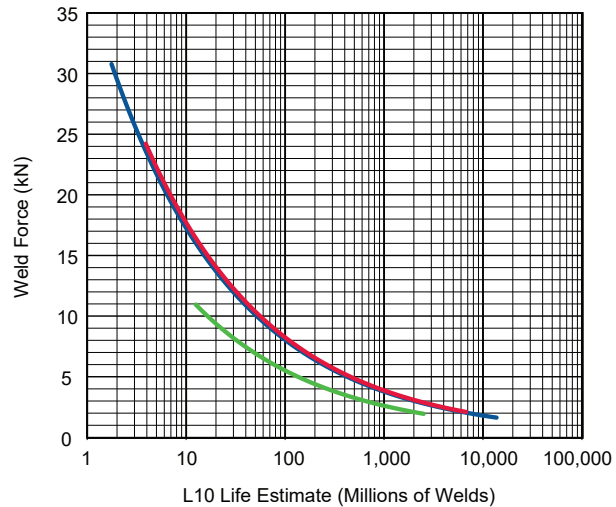

— GTW100-0.1 inch Lead  
 — GTW100-0.2 inch Lead  
 — GTW100-0.5 inch Lead

### Service Life Estimate Assumptions:

- Sufficient quality and quantity of lubrication is maintained throughout service life
- Bearing and screw temperature between 20°C and 40°C

- No mechanical hard stops (external or internal) or impact loads
- No external side loads

## Electrical Specifications

Motor Type		GTW080	GTW100
Motor Voltage		4 (AC)	4 (AC)
Max Bus Voltage	V	460 Vrms	460 Vrms
Speed @ Bus Voltage	RPM	6000	4500**
<b>RMS Sinusoidal Commutation</b>			
Continuous Motor Torque	Nm	4.51	12.23
	lbf-in	39.9	108.2
Continuous Current Rating	A	4.9	12.3
Peak Current Rating	A	9.9	24.7
Torque Constant (Kt) (+/- 10% @ 25°C)	Nm/A	1.02	1.11
	lbf-in/A	9	9.8
Voltage Constant (Ke) (+/- 10% @ 25°C)	V/kRPM	61.6	67
<b>0 - Peak Sinusoidal Commutation</b>			
Continuous Motor Torque	Nm	4.51	12.23
	lbf-in	39.9	108.2
Continuous Current Rating	A	6.9	17.4
Peak Current Rating	A	13.8	34.9
Torque Constant (Kt) (+/- 10% @ 25°C)	Nm/A	0.72	0.78
	lbf-in/A	6.4	6.92
Voltage Constant (Ke) (+/- 10% @ 25°C)	V/kRPM	87.1	94.8
Pole Configuration	Number of Poles	8	8
Resistance (L-L) (+/- 5% @ 25°C)	Ohms	2.5	0.65
Inductance (L-L)(+/- 15%)	mH	17.3	4.6
Electrical Time Constant	ms	6.8	7.1
Insulation Class	460 VAC Max, 180°C (Class H)		

Brake Specifications		GTW080	GTW100
Brake Holding Torque (minimum)	Nm	4.5	11
	lbf-in	40	97
Brake Voltage	VDC	24 (-10%/+6%)	24 (-10%/+6%)
Nominal Brake Current at 24 VDC	A	0.5	0.75
Brake Engage/Disengage Time (typical)	ms	18/35	25/40

Specifications subject to change without notice

Test data derived using NEMA recommended aluminum heatsink at 25°C ambient.

VAC class winding operational from 115 - 460 VAC

Rotational speed linear proportional to input voltage

\* For GTW100 actuators with a 0.1 inch lead, the torque and current must be limited to 8.89 Nm/9.0 Arms not to exceed the force ratings specified in the mechanical specifications table

\*\*Rotational speed mechanically limited to 4500 RPM. Motor is theoretically capable of achieving 6000 RPM at 460 Vrms.

# Speed vs. Force Curves

### GTW080 (0.1 in Lead)

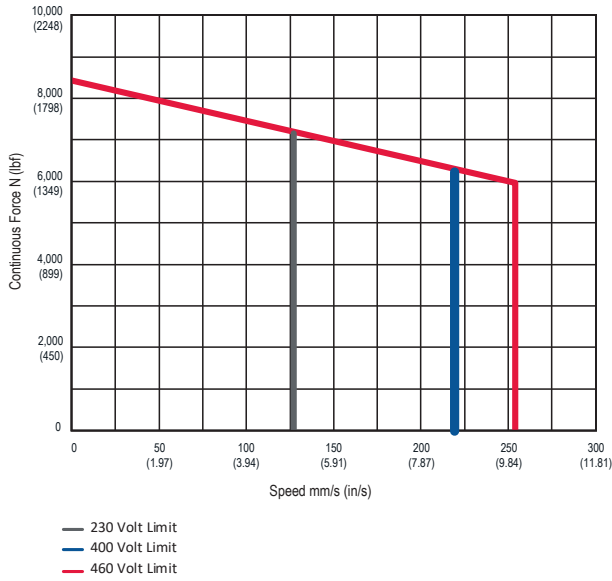

### GTW080 (0.2 in Lead)

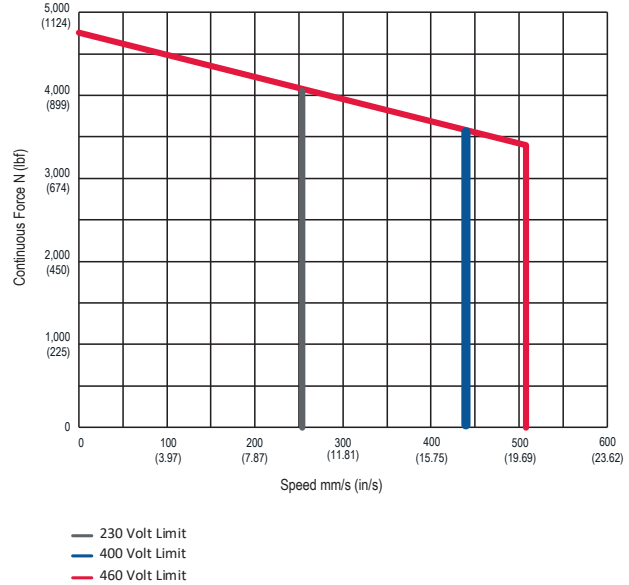

### GTW080 (0.5 in Lead)

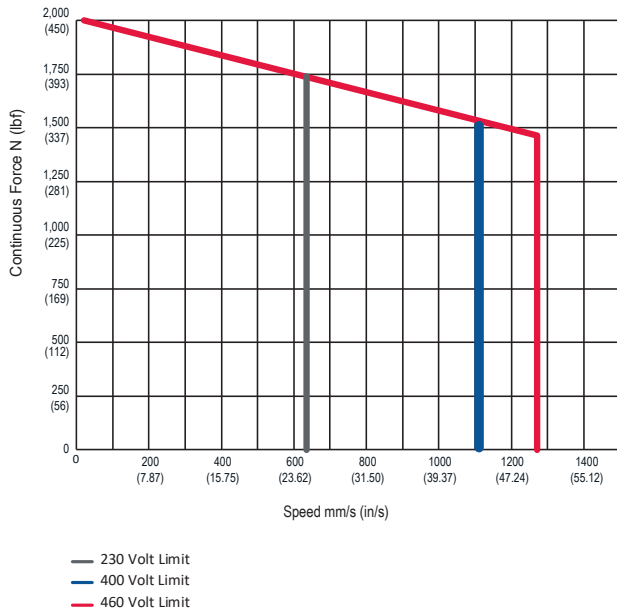

### GTW100 (0.1 in Lead)

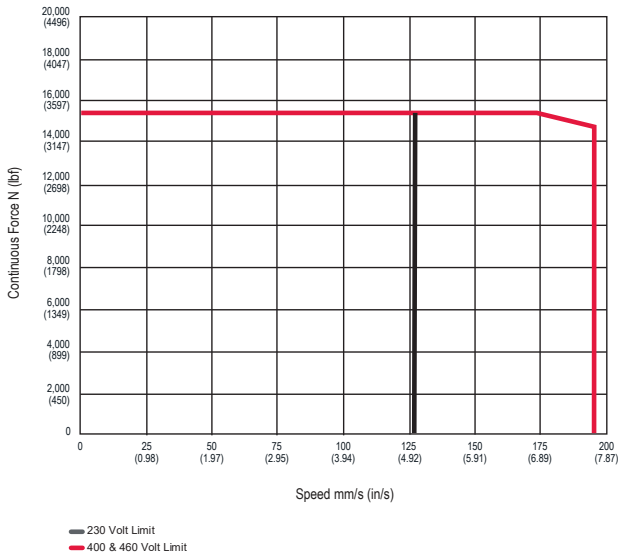

### GTW100 (0.2 in Lead)

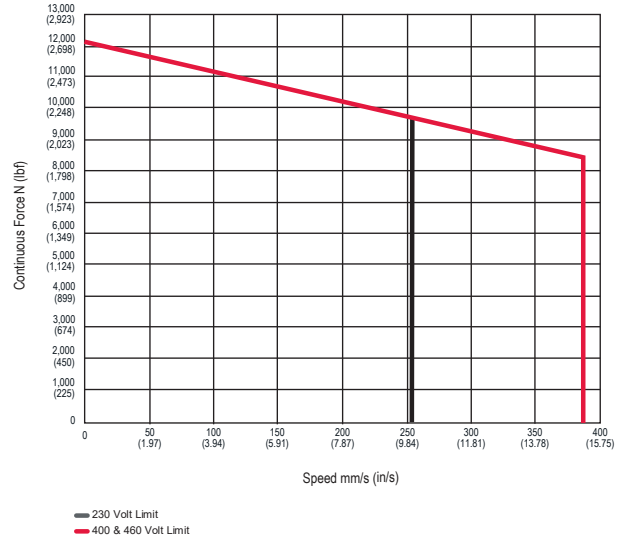

### GTW100 (0.5 in Lead)

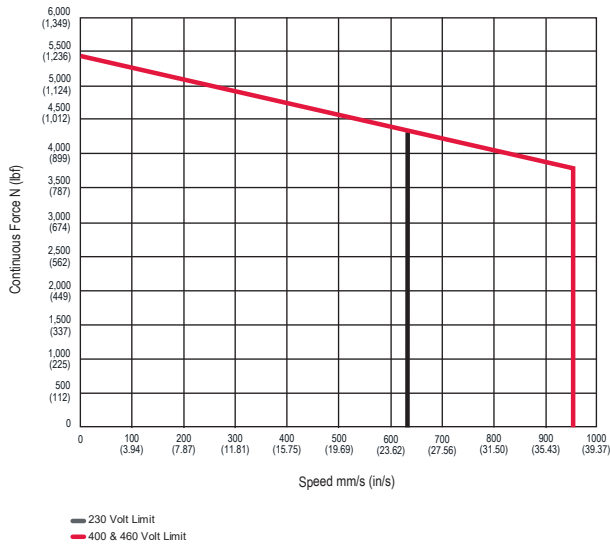

Test data derived using NEMA recommended aluminum heatsink Testing ambient temperature 25°C.  
Curves used for estimation only

## Options

### Robot & Controller Interfaces

GTW actuators are designed for compatibility and integration with the following robot interfaces: ABB, Comau, Fanuc, and KUKA as well as Bosch Rexroth and Festo 7th axis drive controllers.

### Internal Holding Brake

This option provides an internal holding brake for GTW Series actuators. The brake is spring activated and electrically released.

### External Anti-Rotate

The unique design of the GTW Series of linear actuators permits the extending rod to rotate. This capability simplifies setup by allowing the user to rotate the rod in and out of the actuator for mechanical attachment or system testing.

### Internal Anti-Rotate

The splined rod is an internal anti-rotate option that will restrict rotation but still provide linear motion without the need for an external mechanism. The option does not meet the IP66S rating as there is no sealing component where the driven rod extends and retracts. If the unit is installed vertically rod end down there is potential for grease to exit the unit in environments where overheating can occur.

### External Limit Switch / Anti-Rotate Assembly

This option allows external limit switches to be mounted to the GTW Series Actuator. These switches provide travel indication to the controller and are adjustable (Limit switches sold separately).

Switch Type	Exlar Part Number
Normally Closed Switch, PNP	43404
Normally Open Switch, PNP	43403
Normally Closed Switch, NPN	67635
Normally Open Switch, NPN	67634



# Dimensions

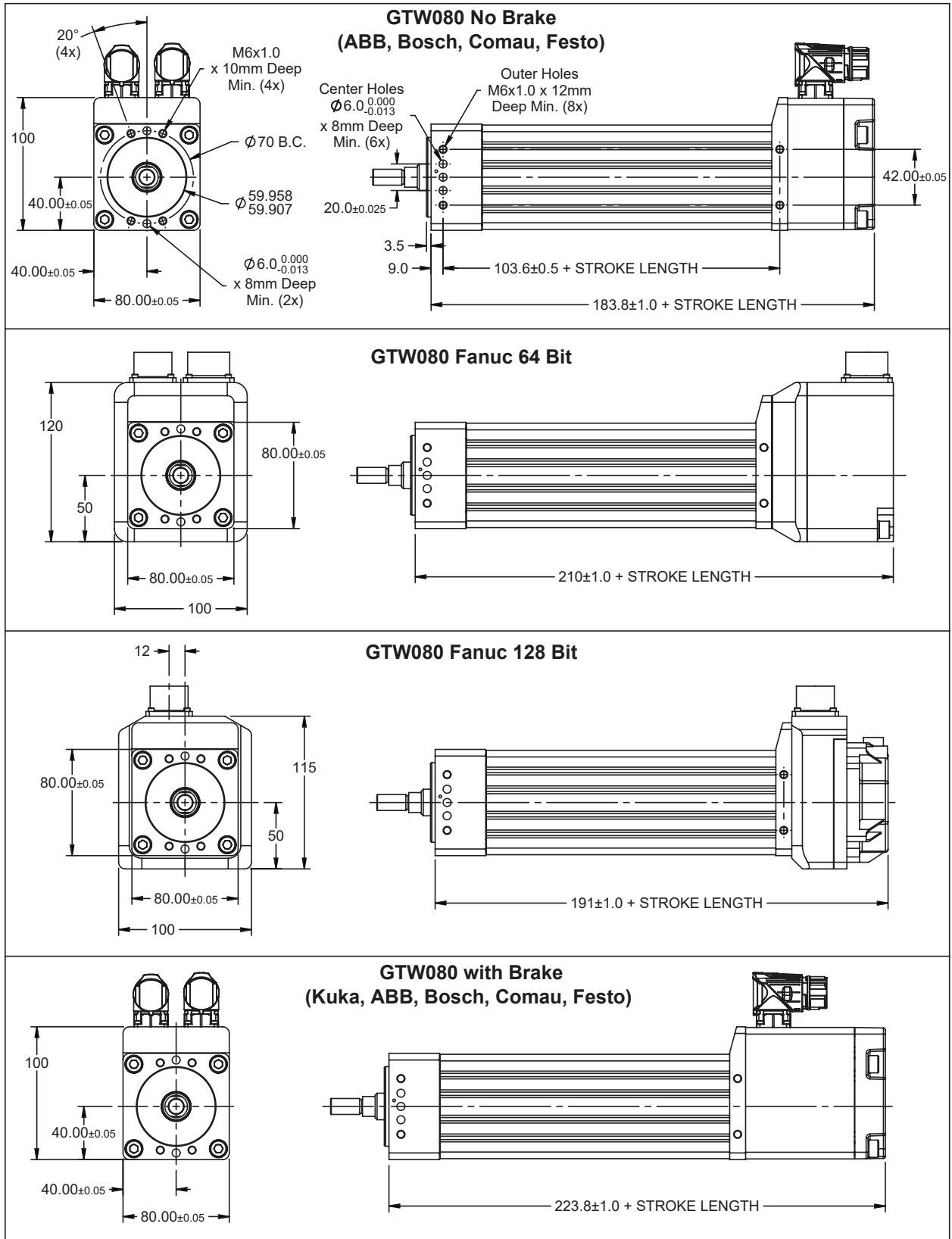

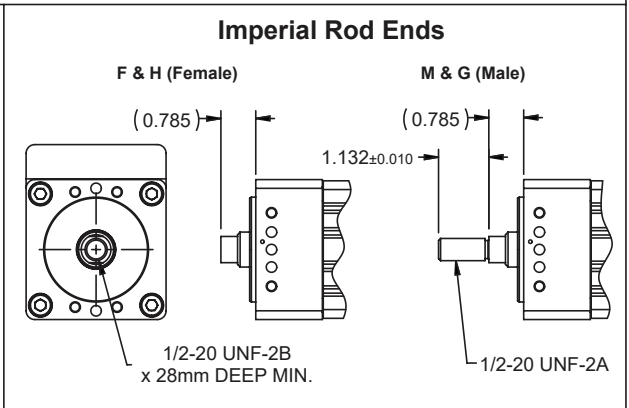
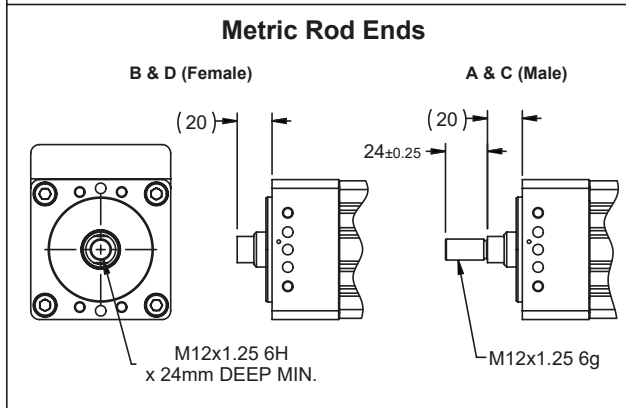
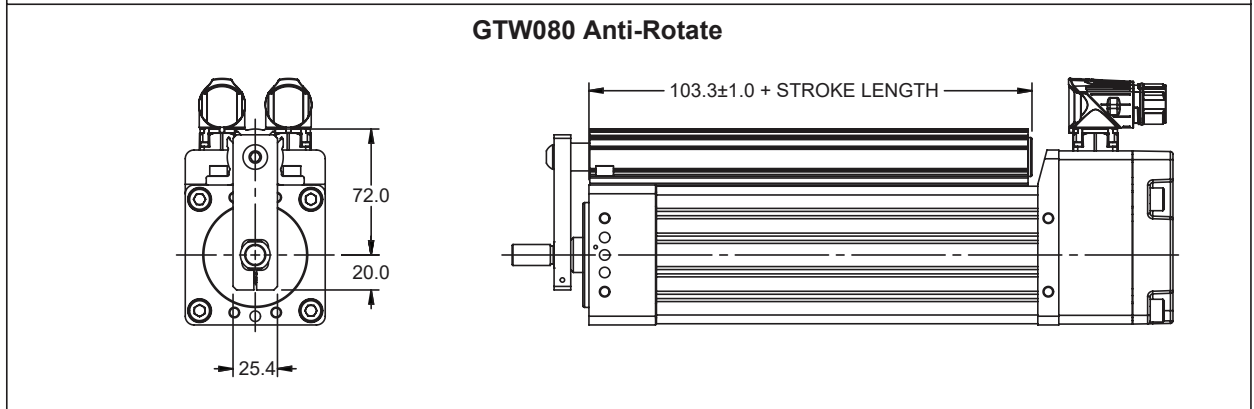
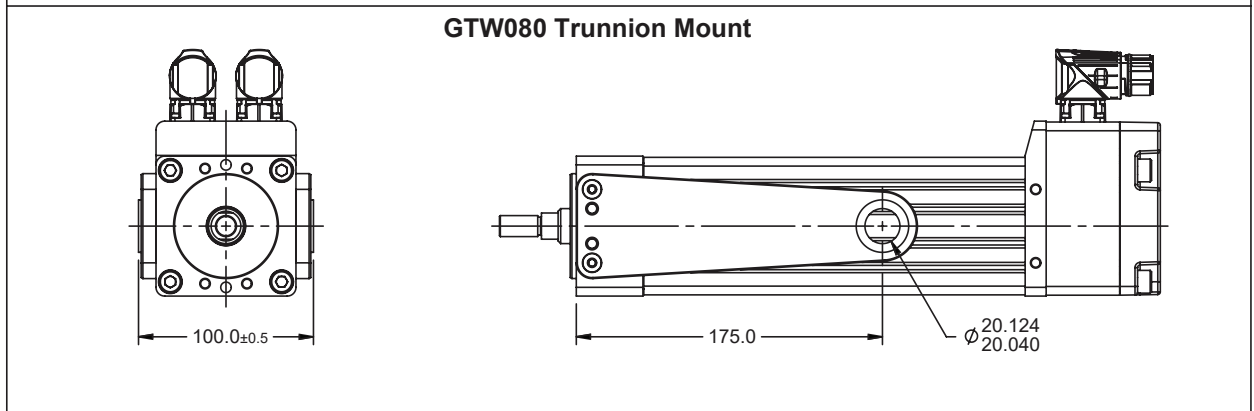
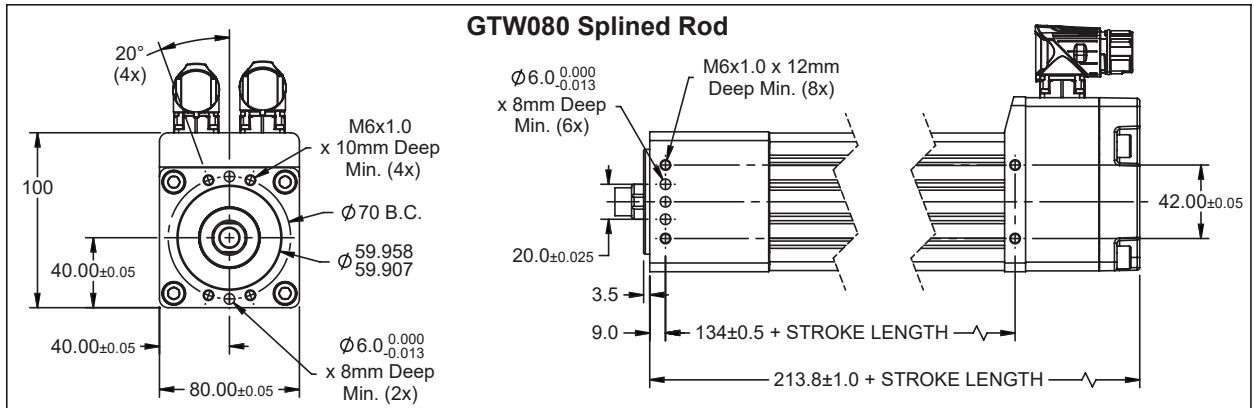

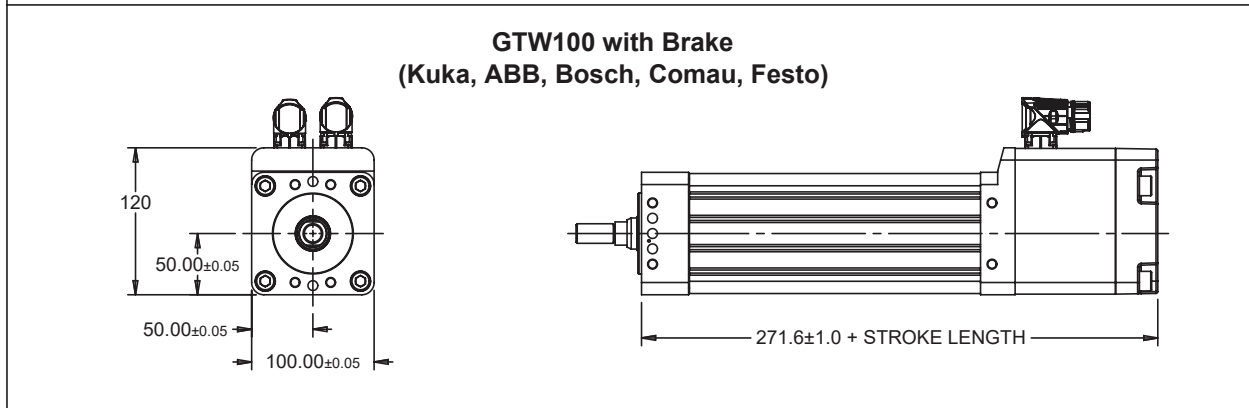
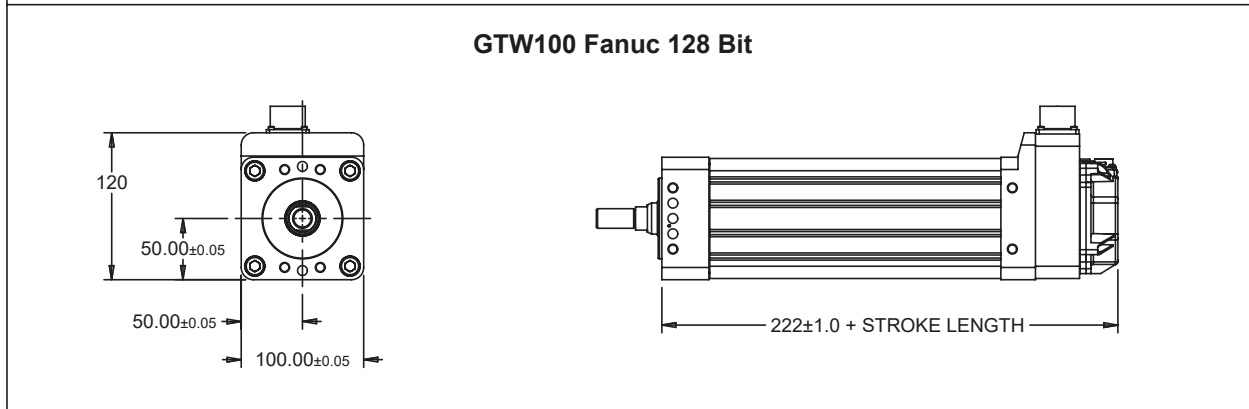
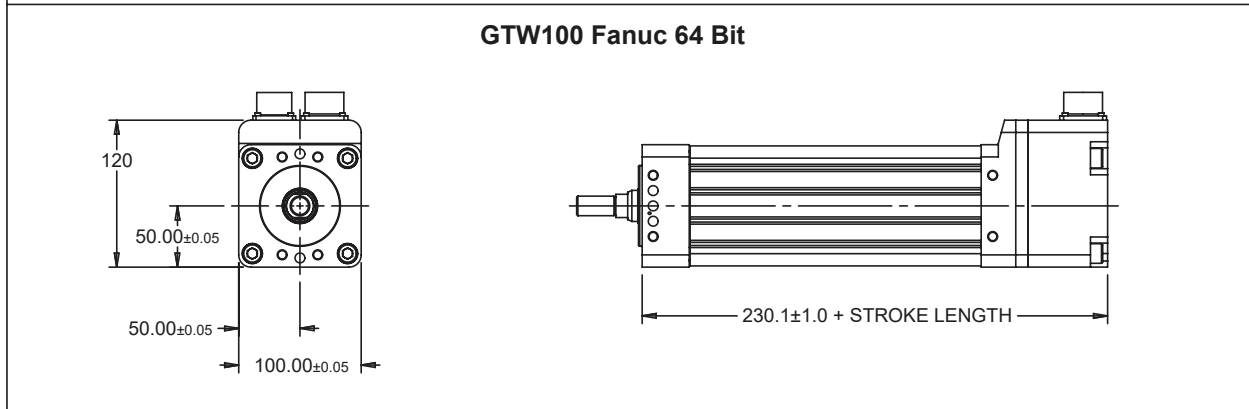
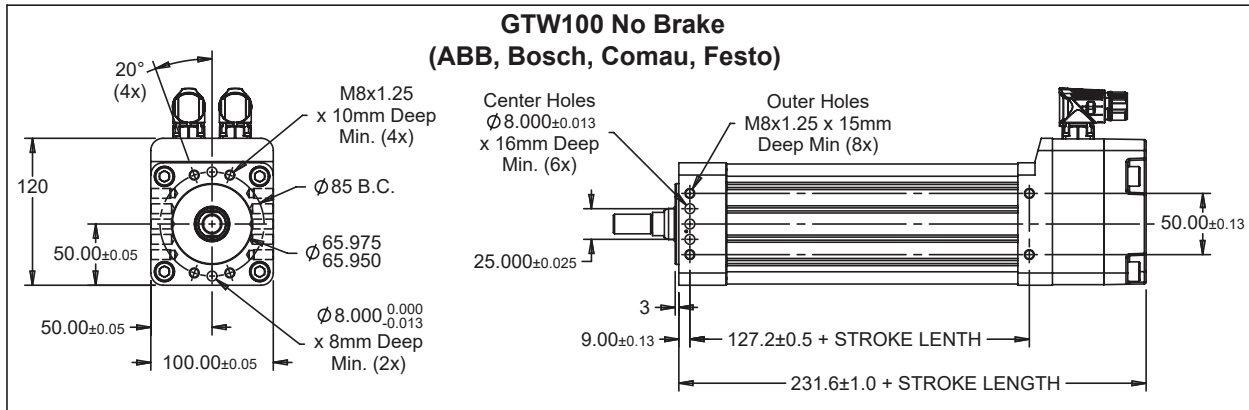

### GTW100 Splined Main Rod

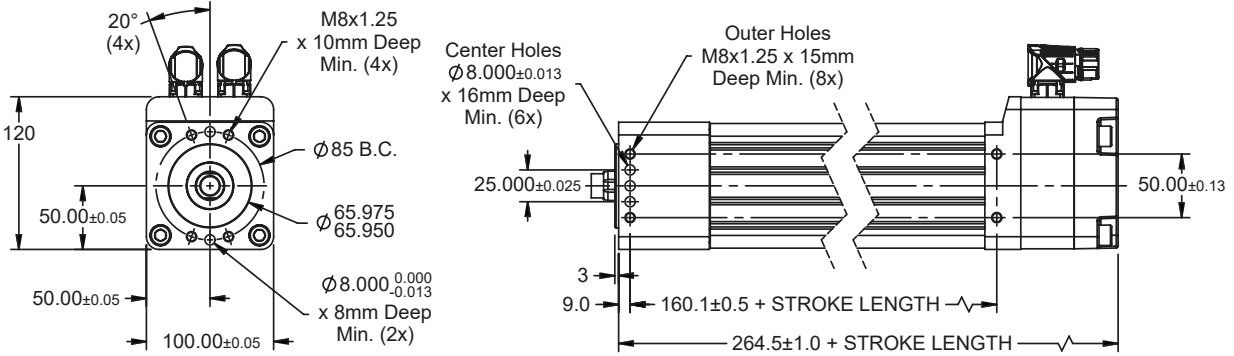

### GTW100 Trunnion Mounting

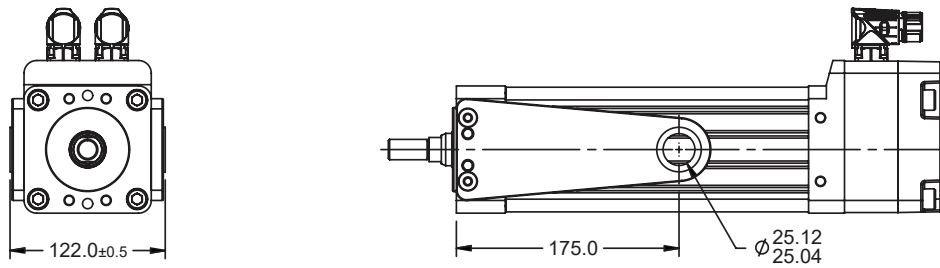

### GTW100 Anti-Rotate

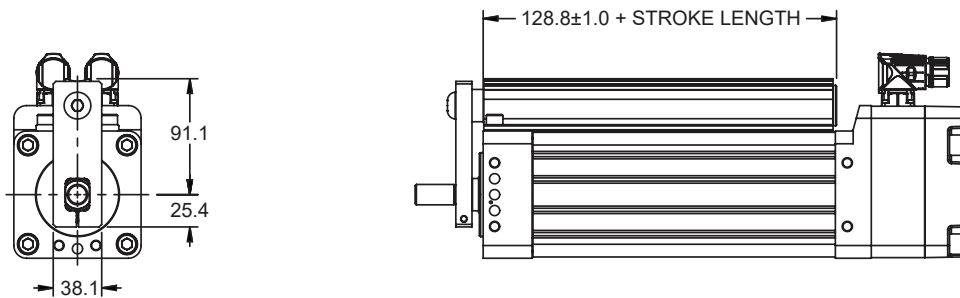

### Metric Rod Ends

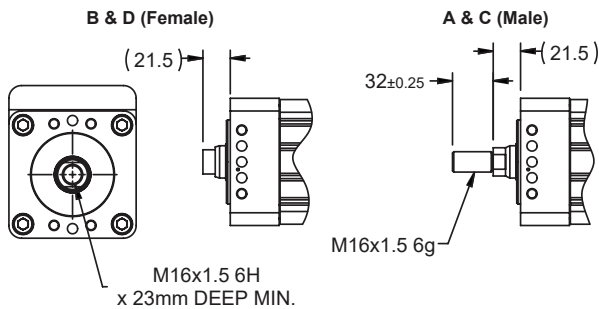

### Imperial Rod Ends

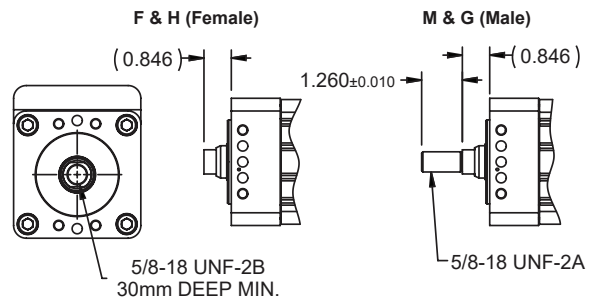

# Order Information

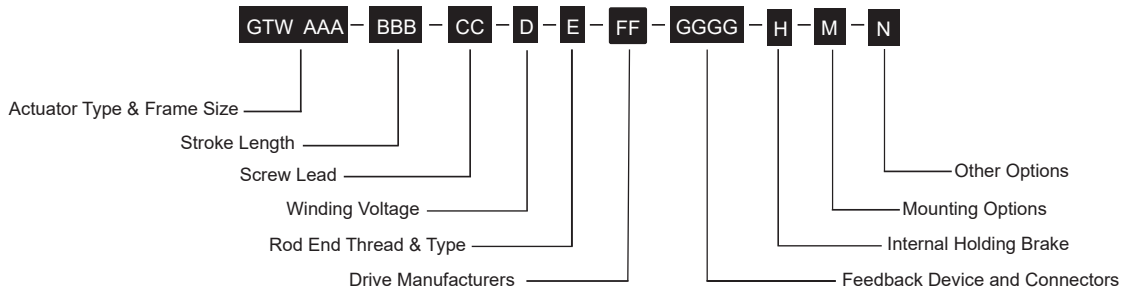

**AAA = GTW Integrated Motor / Actuator**

080 = 80 mm  
100 = 100 mm

**BBB = Stroke Length**

150 = 150 mm  
300 = 300 mm

**CC = Screw Lead**

01 = 0.10 in (2.54 mm)  
02 = 0.20 in (5.08 mm)  
05 = 0.50 in (12.7 mm)

**D = Winding Voltage**

4 = 460 VAC Max

**E = Rod End Thread & Type**

A = Male, Metric  
B = Female, Metric  
C = Male, Metric Splined<sup>1</sup>  
D = Female, Metric Splined<sup>1</sup>  
M = Male, English  
G = Male, English Splined<sup>1</sup>  
F = Female, English  
H = Female, English Splined<sup>1</sup>

**FF = Drive Manufacturer**

AB = ABB  
CM = Comau  
FA = Fanuc (64 & 128 Bit)  
FE = Festo  
IN = Bosch (Indramat)  
KU = KUKA

**GGGG = Feedback Device and Connectors**

See table below

**H= Internal Holding Brake**

N = No Brake  
B = Internal Holding Brake  
(Required for KUKA drive option)

**M = Mounting Options**

N = None  
T = Trunnion

**N = Other Options**

N = None  
A = Anti-Rotate Assembly, External  
L = Limit Switch Housing / Anti-Rotate Assembly

<sup>1</sup> Splined Rod (Internal Anti-Rotate) option reduces IP rating.

Drive Manufacturer	Code	Resolver	Encoder
ABB	AB	R3A4	
Comau	CM	R4B1	
Fanuc 64 Bit (Exlar Supplied)	FA		E2E6
Fanuc 64 Bit (Customer Supplied)	FA		E3E7
Fanuc 128 Bit (Exlar Supplied)	FA		E4F0
Fanuc 128 Bit (Customer Supplied)	FA		E5F0
Festo	FE	R1A1	S1A2
Kuka	KU	R5B1	
Bosch (Indramat)	IN		S2D3



For any special or custom options, please contact Exlar

## Warranty and Limitations of Liability

WARRANTY AND LIMITATION OF LIABILITY: Please see our warranty on our website here: <https://www.cw-actuation.com/About/Group-Policies/Exlar-Terms-and-Conditions-Warranty-and-Limitati> for details.

# Notes

**USA & CANADA**

Exlar Automation  
18400 West 77th Street  
Chanhassen, MN 55317  
Phone: 855-620-6200 (US & Canada)  
Fax: 952-368-4877

**ASIA**

Exlar Asia Pacific  
1007 Pine City Hotel  
8 Dong An Road, Xuhui District  
Shanghai 200032 China  
Phone: +86 021-6495-7868

***CURTISS -  
WRIGHT***

**EXLAR<sup>®</sup>**

**[www.exlar.com](http://www.exlar.com)**