

FT Series – Oil Bath Lubrication

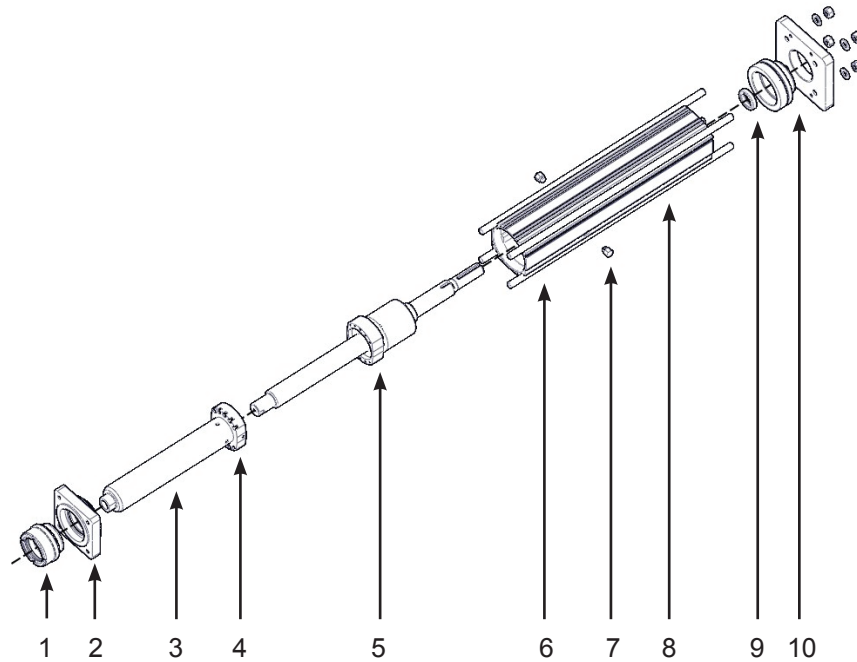

Shown above is an exploded view of the FT Series actuator base unit.

Often, for high cycle rate or high speed applications, oil bath lubrication is used in place of the standard grease lubrication of the roller screw and bearings. The advantage of oil is that it bridges the air gaps within the unit allowing more efficient heat transfer from the load carrying components, the roller screw and the bearings to the case. The other advantage to oil bath lubrication is that it allows for fill and drain ports to be located on the unit to allow the user to replace the lubrication without having to open the unit up as would be required to remove and replace old grease.

The force tube assembly consists of an actuator case (8). Within this case are located the thrust bearings and planetary roller screw of the actuator. This case is the main vessel which will contain the lubricating oil. The actuators main extending rod, (3) attaches to the nut of the roller screw (5) and when the screw shaft rotates, the nut travels on the threaded screw shaft moving the main rod in and out of the actuator. The main rod is hollow. The outer diameter of the main rod is sealed with a high pressure jewel oil seal and bushing assembly (1) as it exits the actuator. The actuator housing is o-ring sealed at the face plate (2) and end plate (10) and the rotating screw shaft is sealed with a high speed, high pressure shaft seal (9).

The case of the actuator is provided with ports (6) that are regularly plugged with sealing plugs (7). These ports provide the user access to fill and drain the oil from the actuator. These ports are located in coordination with information from the customer such that the location of the ports, and the orientation of the actuator allow the ports to provide proper fill and drain access.

The main rod is moving in and out of the actuator. As it moves out, being hollow, the available volume for oil to be contained increases. When it retracts, that volume decreases, and some of the oil has moved into the main rod. To allow this oil to easily escape the main rod, 4 relief holes (4) are provided near the rod flange.

Other details are required from the user to properly configure the FT for use with oil bath lubrication. The orientation of mounting, as well as the expected beginning and ending positions of the main rod in normal operation allow the proper amount of oil fill to be defined. Defining the proper amount of oil allows for a fill volume that provides lubrication to the screw shaft, nut and bearings as needed, without providing possible interference to motion by being overfilled. The proper fill volume is indicated on the actuator prints.