

### Product Comparison: GTX vs GSX

GTX Series actuators are energy efficient, compact robust solutions that are an ideal alternative to fluid power mechanics. Capable of high force, high duty cycle applications the GTX has output forces of up to 15.3 kN (3,460 lbf) and speeds up to 1,270 mm/sec (50 in/sec). Available in a stroke length range of 80 mm – 450 mm varying across three frames sizes the GTX series can be applied across a wide range of linear motion applications.

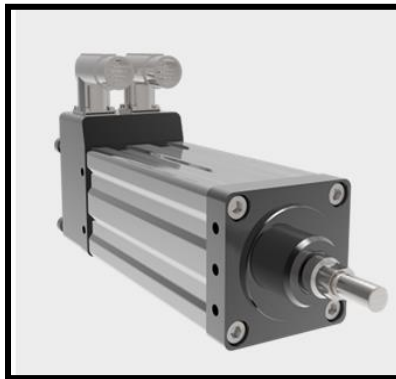

The GTX features the following key benefits over the predecessor GS designs:

- 4X life with redesigned roller screw GTX100 vs GSX40.
- 30% increased force density GTX080 vs GSX30
- IP66S (static) rated with improved seal and wiper design.
- Modular design for bolt-on accessories.
- AC/DC stator options that support a wide range of force and speed outputs.
- Flexible mounting options.
- Standard and configured stroke length options available in 25 mm increments.

## Feature Benefits over GSX

Feature Benefits Comparison			
Description	GSX	GTX	GTX Benefit
Roller Screw Nut Assembly	Full roller compliment	Full roller compliment (standard)	Improved life and reliability/Increased force density
IP Rating	IP65	IP66S	Suitable for wash down with static ingress protection
Stator Design	1-3 stacks	AC standard/DC available (3 stacks standard)	Covers all output force ranges with option
Connectors	Varied Options	Right Angle Rotatable M23 (standard)	Aligned mounting orientation/ streamlined connections
Actuator Mounting Features	Permanent	Modular	Field-Replaceable, Flexible Options
Front Plate Sealing	FSB	Integrated Seal Wiper System	Field-Replaceable, Simplified Maintenance
<b>Main Rod Diameter</b>			
GSX20 vs GTX060	12.7 mm (.50 in)	12.7 mm (.50 in)	
GSX30 vs GTX080	15.9 mm (.63 in)	20 mm (.78 in)	Stronger/Stiffer
GSX40 vs GTX100	25.4 mm (1.0 in)	25.4 mm (1.0 in)	
<b>Tie Rods</b>			
GSX20 vs GTX060	1/4-20 UNC-2A	M6 X 1.0 (18 mm) SHCS, SS	Stronger/Stiffer
GSX30 vs GTX080	1/4-20 UNC-2A	M8 X 1.25 (25 mm) SHCS, SS	Stronger/Stiffer
GSX40 vs GTX100	3/8-16 UNC-2A	M10 X 1.5 (30 mm) SHCS, SS	Stronger/Stiffer

## Mechanical Specs Comparison

GTX Mechanical Specifications		
Model	Continuous Force	Max Speed
	N (lbf)	mm/sec (in/sec)
GTX060	AC -2,688 (600)	AC -1,270 (50)
	DC - 2,688 (600)	DC - 847 (33.3)
GTX080	AC -8,365 (1,881)	AC -1,270 (50)
	DC - 7,101 (1,596)	DC - 508 (20)
GTX100	AC -15,392 (3,460)	AC -953 (37.5)

GSX Mechanical Specifications		
Model	Continuous Force	Max Speed
	N (lbf)	mm/sec (in/sec)
GSX20	AC -2,600 (575)	AC -846 (33)
GSX30	AC -5,680 (1,277)	AC -635 (25)
GSX40	AC -15,375 (3,457)	AC -953 (37.5)

# GSX and GTX Dimensional Comparisons

## Catalog Option (N) Base Unit

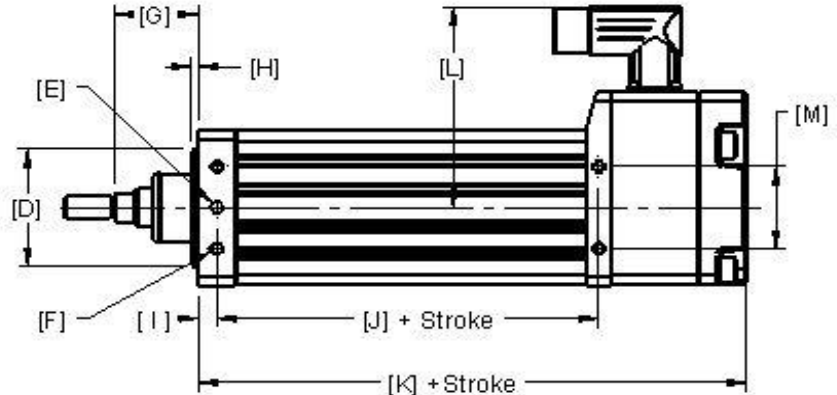
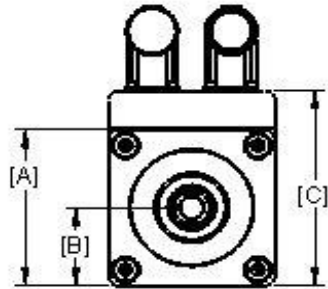

\*[G] Dimension shown at fully retracted position.

		GSX20	GTX060	GSX30	GTX080	GSX40	GTX100
A	in	2.24	2.36	3.05	3.14	3.90	3.93
	mm	56.9	60.0	77.4	80	99.10	100
B	in	1.12	1.18	1.52	1.57	1.95	1.96
	mm	28.4	30.0	38.7	40	49.50	50
C	in		3.14		3.93		4.72
	mm	N/A	80.0	N/A	100	N/A	120
Ø D	in	1.500+0.00/- 0.03	1.652/1.650	2.000+0.00/- 0.03	2.361/2.358	2.500+0.00/- 0.03	2.755/2.753
	mm	38.10+0.00/- 0.08	41.97/41.93	50.80+0.00/- 0.08	59.97/59.90	63.50+0.00/- 0.08	69.98/69.95
Ø E	in		6.000/5.987 x 8mm Deep		6.000/5.987 x 8mm Deep		8.000/7.987 x 14mm Deep
	mm	N/A		N/A		N/A	
Ø F	in		M6X1.0 x 12 mm Deep		M6X1.0 x 12 mm Deep		M8X1.25 x 16 mm Deep
	mm	N/A		N/A		N/A	
G	in	1.00	1.26	1.32	1.57	1.65	1.57
	mm	25.4	32	33.5	40	41.9	40
H	in	0.140	0.118	0.090	0.138	0.100	0.118
	mm	3.7	3.0 ±0.13	2.3	3.5 ±0.13	2.50	3 ±0.13
I	in		0.236		0.354		0.393
	mm	N/A	6 ±0.13	N/A	9 ±0.13	N/A	10 ±0.13
J	in		2.95		3.287		4.232
	mm	N/A	75.0 ±0.5	N/A	83.5 ±0.5	N/A	107.5 ±0.5
K	in	4.8	6.33	5.2	6.437	6.6	8.405
	mm	122	160.9 ±1.0	133	163.5 ±1.0	167	213.5 ±1.0
L	in		3.78		4.173		4.37
	mm	N/A	96	N/A	106	N/A	111
M	in		1.18		1.653		1.968
	mm	N/A	30 ±0.13	N/A	42 ±0.13	N/A	50 ±0.13

## Catalog Option (1) Metric Front Flange

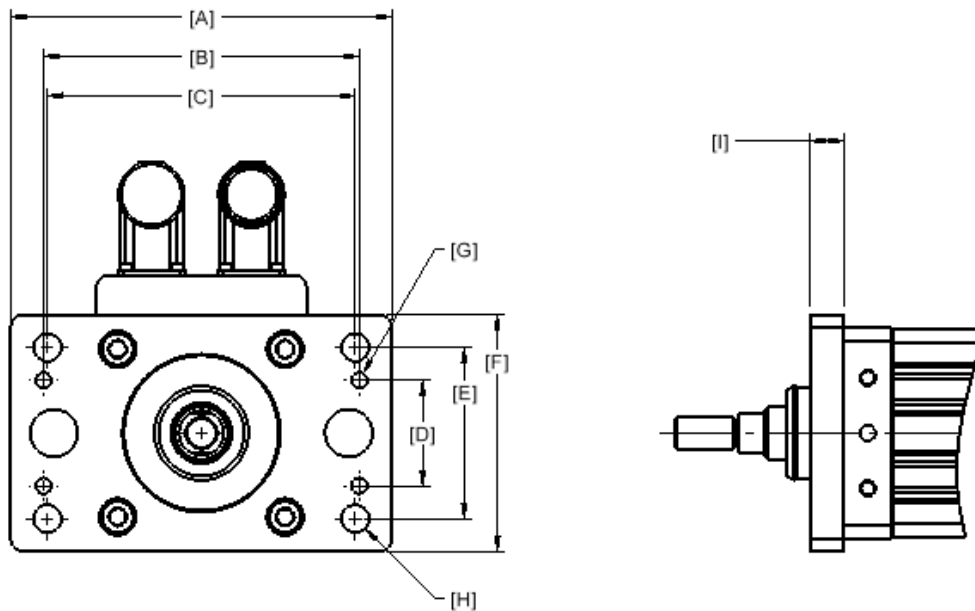

		GSX20	GTX060	GSX30	GTX080	GSX40	GTX100
A	in	3.75	4.33	5.94	5.70	7.68	7.09
	mm	95.3	110 ±0.13	150.9	145 ±0.13	195.10	180 ±0.13
B	in	3.13	2.51	3.69	4.72	5.25	5.11
	mm	79.4	64 ±0.025	93.7	120 ±0.025	133.40	130 ±0.13
C	in	3.13	3.43	5.250 ±.005	4.60	6.800 ±.005	5.86
	mm	79.4	87 ±0.13	133.35	117 ±0.13	172.72	149 ±0.025
D	in	1.00	0.945	2.43	1.57	2.92	2.36
	mm	25.4	24 ±0.025	61.7	40 ±0.025	74.20	60 ±0.025
E	in	1.75	1.61	2.43	2.55	2.92	3.26
	mm	44.5	41 ±0.13	61.7	65 ±0.13	74.20	83 ±0.13
F	in	2.24	2.36	3.05	3.54	3.80	4.52
	mm	56.8	60 ±0.13	77.4	90 ±0.13	96.50	115 ±0.13
Ø G	in	.125 ±.001	NA	.250 ±.001	N/A	.250 ±.001	N/A
	mm	3.18 ±.03	6.000+0.025/- 0.000	6.35 ±.013	6.000+0.025/- 0.000	6.35 ±.025	6.000+0.025/- 0.000
Ø H	in	0.250	N/A	0.397	N/A	0.516	N/A
	mm	6.35	8.5 ±0.13	10.08	10.5 ±0.13	13.10	12.5 ±0.13
I	in	0.44	0.512	0.44	0.512	0.63	0.748
	mm	11.1	13 ±0.25	11.1	13 ±0.25	15.90	19 ±0.25

## Catalog Option (5) Metric Rear Clevis

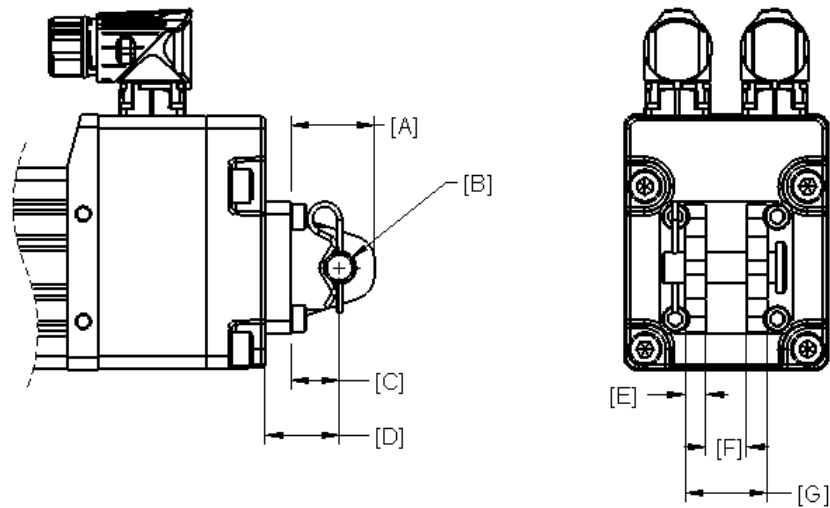

		GSX20	GTX060	GSX30	GTX080	GSX40	GTX100
<b>A</b>	in	N/A	0.91	N/A	1.30	N/A	1.42
	mm	N/A	23 ±0.25	N/A	33 ±0.25	N/A	36 ±0.25
<b>Ø B</b>	in	0.500 +0.002/-0.000	0.4	0.750+0.002/- 0.001	0.47	0.750+0.002/- 0.001	0.63
	mm	12.7	10 H9	19.1	12 H9	19.1	16 H9
<b>C</b>	in	0.750±0.010	0.51	1.250±0.010	0.74	1.250±0.010	0.87
	mm	19.1	13±0.13	31.8	19±0.13	31.8	22±0.13
<b>D</b>	in	1.065±0.010	0.87	1.644±0.010	1.14	1.722±0.010	1.34
	mm	27.1	22±0.25	41.8	29±0.25	43.7	34±0.25
<b>E</b>	in	0.375±0.005	0.24	0.625±0.005	0.31	0.625±0.005	0.39
	mm	9.5	6±0.13	15.9	8±0.13	15.9	10±0.13
<b>F</b>	in	0.750±0.005	0.47	1.250±0.005	0.63	1.250±0.005	0.79
	mm	19.1	12±0.13	31.8	16±0.13	31.8	20±0.13
<b>G</b>	in	1.500±0.010	0.94	2.500±0.010	1.26	2.500±0.010	1.57
	mm	38.1	24±0.25	63.5	32±0.25	63.5	40±0.25

## Catalog Option (F) Inch Front Flange (GSX Equivalent)

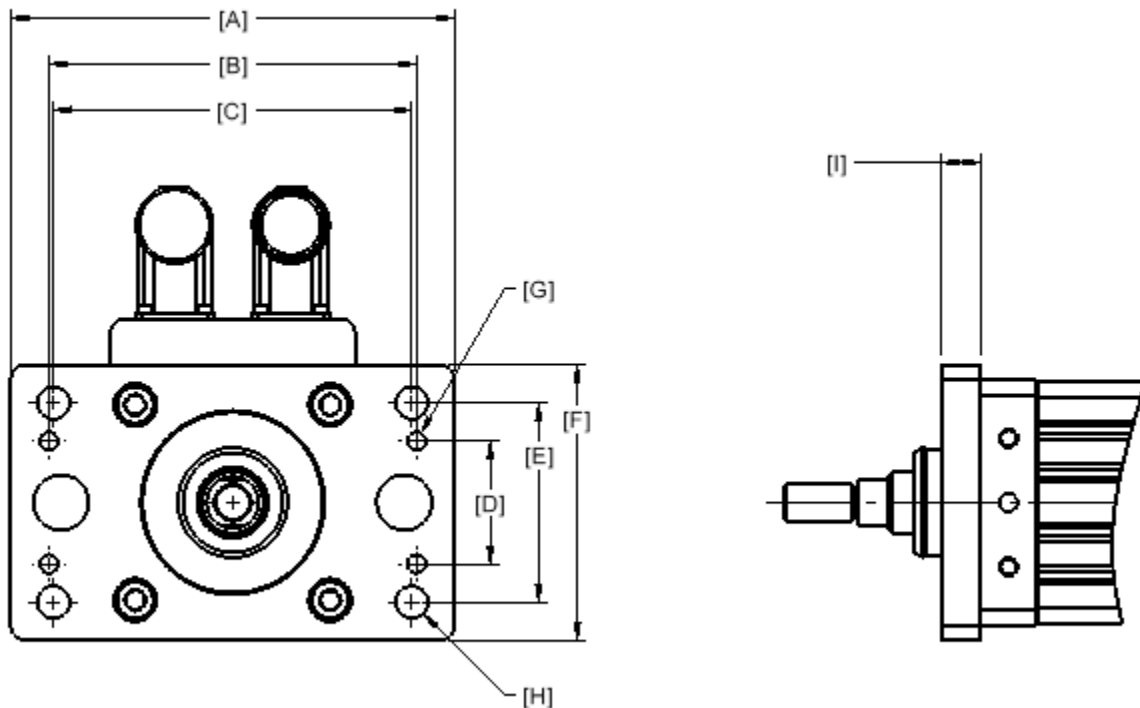

		GTX060	GTX080	GTX100
A	in	3.75	5.94	7.68
	mm	95.3	150.9	195.10
B	in	3.13	3.69	5.25
	mm	79.4	93.7	133.40
C	in	3.13	5.250 ± .005	6.800 ± .005
	mm	79.4	133.35	172.72
D	in	1.00	2.43	2.92
	mm	25.4	61.7	74.20
E	in	1.75	2.43	2.92
	mm	44.5	61.7	74.20
F	in	2.24	3.05	3.80
	mm	56.8	77.4	96.50
Ø G	in	.125 ± .001	.250 ± .001	.250 ± .001
	mm	3.18 ± .03	6.35 ± .013	6.35 ± .025
Ø H	in	0.250	0.397	0.516
	mm	6.35	10.08	13.10
I	in	0.44	0.44	0.63
	mm	11.1	11.1	15.90

## Catalog Option (C) Inch Rear Clevis (GSX Equivalent)

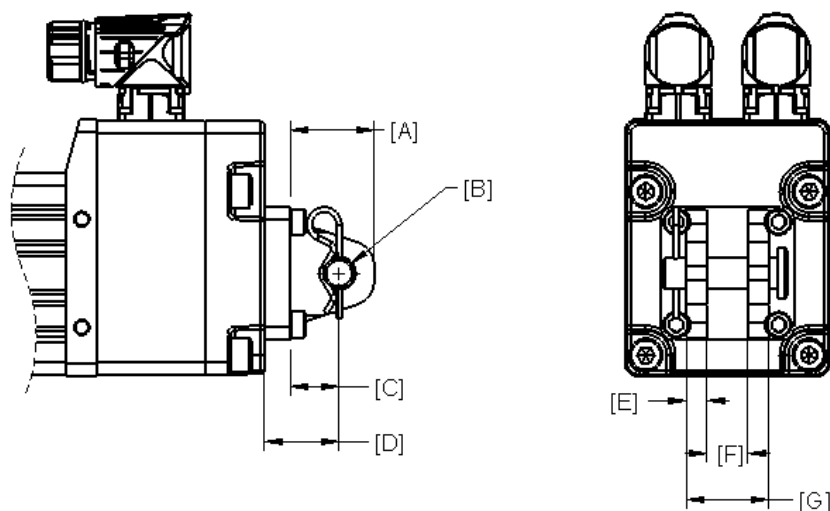

		GTX060	GTX080	GTX100
A	in	N/A	N/A	N/A
	mm	N/A	N/A	N/A
Ø B	in	0.500+0.002/-0.000	0.750+0.002/-0.001	0.750+0.002/-0.001
	mm	12.7	19.1	19.1
C	in	0.750±0.010	1.250±0.010	1.250±0.010
	mm	19.1	31.8	31.8
D	in	1.065±0.010	1.644±0.010	1.722±0.010
	mm	27.1	41.8	43.7
E	in	0.375±0.005	0.625±0.005	0.625±0.005
	mm	9.5	15.9	15.9
F	in	0.750±0.005	1.250±0.005	1.250±0.005
	mm	19.1	31.8	31.8
G	in	1.500±0.010	2.500±0.010	2.500±0.010
	mm	38.1	63.5	63.5

## Catalog Option (3) Metric Tapped Face

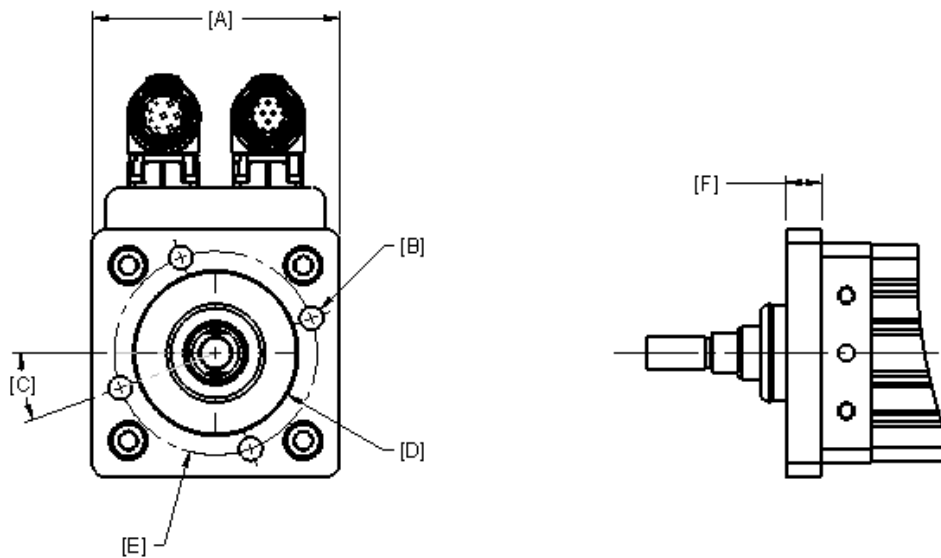

		GTX060	GTX080	GTX100
A	mm	63 ±0.25	90 ±0.25	110 ±0.25
	in	2.48	3.54	4.33
∅ B	mm	M8X1.25 x 16 mm	M10X1.5 x 13 mm	M12X1.25 x 19 mm
C	Deg	27° ±0.5	20° ±0.5	20° ±0.5
D	mm	59 BC	74 BC	91 BC
E	mm	12 ±0.25	13 ±0.25	19 ±0.25
	in	0.47	0.51	0.74