

Tritex[®] EVA080 Product Catalog

Intelligent Electric Valve Actuator

**CURTISS -
WRIGHT**
EXLAR[®]

Specifications

Drawings

Ordering

And More...

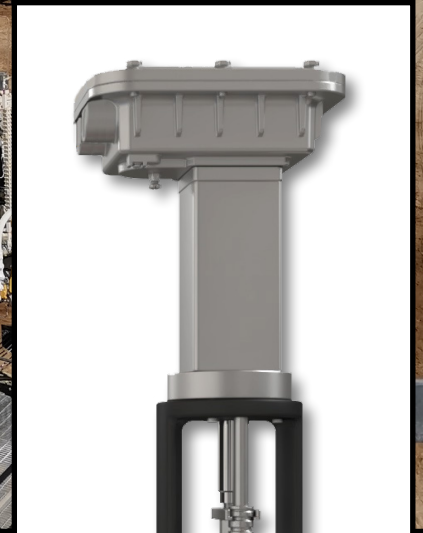

Intelligent Tritex[®] EVA080
Electric Valve Actuator

Power | Precision | Proven

September 2024

Table of Contents

Three Decades of Electric Actuation.....	3
Oil & Gas Industry Regulations	4
Tritex EVA080 CSA Certification: C1D2.....	5
Electric vs. Pneumatic Valve Actuators	6
Key Product Advantages.....	7
Tritex EVA Product Information	8
Features & Benefits	8
Connection Basics	9
Expert Software	10
Valve Adapter Kit	11
Speed & Endurance.....	12
Electric Valve Actuator Selection & Thrust Load.....	13
Dimensions	14
Upstream Oil & Gas Applications	16
Ordering Information.....	17

The need to reduce methane emissions is challenging the Oil & Gas Industry

EXLAR

QR Code

Watch Video

Pneumatic valve actuation is a common source of emissions in upstream applications

Play 00:10

Step-by-Step with Tritex EVA080

Eliminate emissions by replacing pneumatic systems with the new **Tritex EVA080** electric valve actuators. Performance benefits are outlined in the video and system integration is clearly explained.

EXLAR: Three decades of highly reliable electric actuation

Changing the Game. Exlar has engineered highly reliable electric actuation for three decades beginning with the invention of the first electric inverted roller screw servo actuator. Exlar actuators have been used as critical components to many automation markets, including Automotive, Defense, Food & Beverage, and Oil & Gas, where an explosion proof version was developed resulting in superior performance.

Electric Valve Actuation Innovation. High-performance electric actuators with a roller screw drive train from Curtiss-Wright Exlar offer superior life and reliability that exceeds the rugged demands of the process industry. For over 25 years Exlar has been a leader in electric valve control actuation, beginning with its first explosion proof valve actuator introduced in 1996 until today.

In 2013 Exlar introduced the general purpose Tritex® TDM075 actuator with integrated electronics to Upstream Oil & Gas applications. It achieved **hazardous location certification**, offering the first electric actuation solution that exceeded the performance of existing pneumatic actuators. Now — a decade later — another breakthrough product is introduced, the Tritex® EVA080 electric valve actuator. It is the most rugged Tritex configuration to date.



1993 The Exlar Inverted Roller Screw

The Exlar inverted roller screw servo actuator was designed to be a high-performance, highly reliable actuation solution.



2013 Upstream Oil & Gas Actuators

The Tritex TDM075 with integrated servo drive and actuator certified to CSA C1D2 hazardous location provides a high-performance, low maintenance solution.



2023 Meeting Strict Industry Standards

Based on the same core technology as previous Tritex products, the Tritex EVA080 is optimized for valve control in outdoor hazardous environments.

Tritex® EVA080

- Meets Industry Regulations
- CSA Certified: C1D2
- NEMA 4X Environmental Protection
- Easy Installation
- Low Maintenance

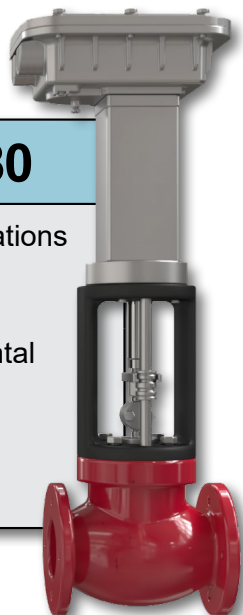

The **Tritex® EVA080** is a high-performance, high-speed actuator designed to meet today's zero emissions industry regulations. With this new innovation, you can meet today's strict regulations without compromising performance or speed when switching from pneumatic to electric.

Oil & Gas Industry Regulations

REGULATIONS

Controlling Air Pollution. Methane — a *global warming greenhouse gas* — is the largest industrial source of emissions of volatile organic compounds (VOCs). The U.S. Environmental Protection Agency (EPA) states that one third of the warming from greenhouse gases occurring today is due to human-caused emissions of methane ⁽¹⁾.

According to the EPA, the largest source of methane emissions in the United States comes from the oil and natural gas industry ⁽²⁾. Through the **Clean Air Act** and **Methane Emissions Reduction Program (MERP)**, the EPA has the responsibility and authority to sharply cut methane pollution.

Quad-0 Regulation. In 2011 the EPA introduced the Code of Federal Regulations 40, Part 60, Subpart 0000 (Quad-0) which significantly tightened the regulations on the oil & gas industry. Originally applied to new or modified facilities the regulation has expanded over the years to encompass more sites and applications. Quad-0 will continue to expand with the implementation of the proposed 0000c which is expected to go in effect late 2023 and for the first time will effect existing installations.

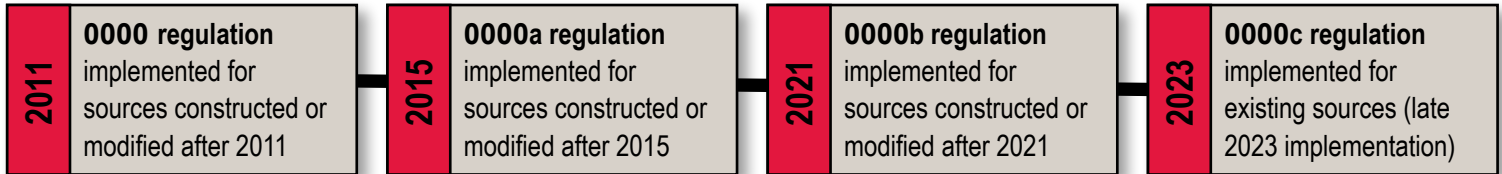

MERP. Implemented in 2022 MERP was designed to complement the EPA's Quad-0 regulation by filling in regulation gaps with the goal of further reducing methane emissions. MERP contains both financial incentives in the form of funding as well as imposes incrementally increasing charges for waste emissions starting in 2024 (\$900 to \$1,500 per ton by 2026) for waste emissions above thresholds.

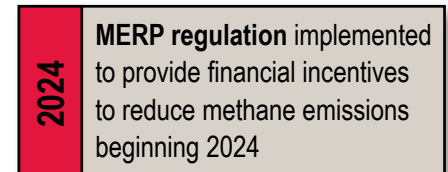

Tritex EVA solutions for Quad-O and MERP

Zero-Emissions Solutions	Remote Monitoring & Control	Increase Efficiency
<p>Compliant with Code of Regulations 40 Part 60, Subpart 0000 (Quad-0)</p> <div style="display: flex; align-items: center;"> <p>Electric actuation is a no-bleed solution that eliminates venting gas to the atmosphere</p> </div> <p>Reduced compliance paperwork due to zero emissions</p>	<p>Remotely monitor cycle count for preventive maintenance scheduling through Modbus RTU (RS-485)</p> <div style="text-align: center; margin: 20px 0;"> </div> <p>Remotely monitor diagnostics and status log for easy maintenance serviceability</p>	<p>Low maintenance, long actuator life solution ensures reliable actuation and high uptime</p> <div style="display: flex; justify-content: space-around; margin: 20px 0;"> <div style="text-align: center;"> <p>High Performance</p> </div> <div style="text-align: center;"> <p>Low Maintenance</p> </div> </div> <p>Servo motor control yields high-efficiency energy consumption</p>

¹ U.S. to Sharply Cut Methane Pollution | US EPA. www.epa.gov/newsreleases/us-sharply-cut-methane-pollution-threatens-climate-and-public-health

² Importance of Methane | US EPA. www.epa.gov/gmi/importance-methane

Tritex EVA080 CSA Certification: C1D2

The CSA group (formerly the Canadian Standards Association; CSA) is an independent organization that provides testing and approval of products for use in hazardous locations in North America (United States and Canada).

Electric Solutions in Hazardous Locations. Understanding hazardous locations is an important task for any company in the oil & gas, process industry. Because an electric solution eliminates the venting of combustible gas it's possible that the location can be re-evaluated to a different hazardous location class.



Where ignitable concentrations of flammable gases, vapors, or liquids:	
Class 1, Division 2	Class 1, Division 1
Are NOT likely to exist under normal operating conditions	Are likely to exist under normal operating conditions
Are normally in closed containers where the hazard can only escape through accidental rupture or breakdown of such containers or in case of abnormal operation of equipment	Exist frequently because of maintenance and repair work or frequent equipment failure.

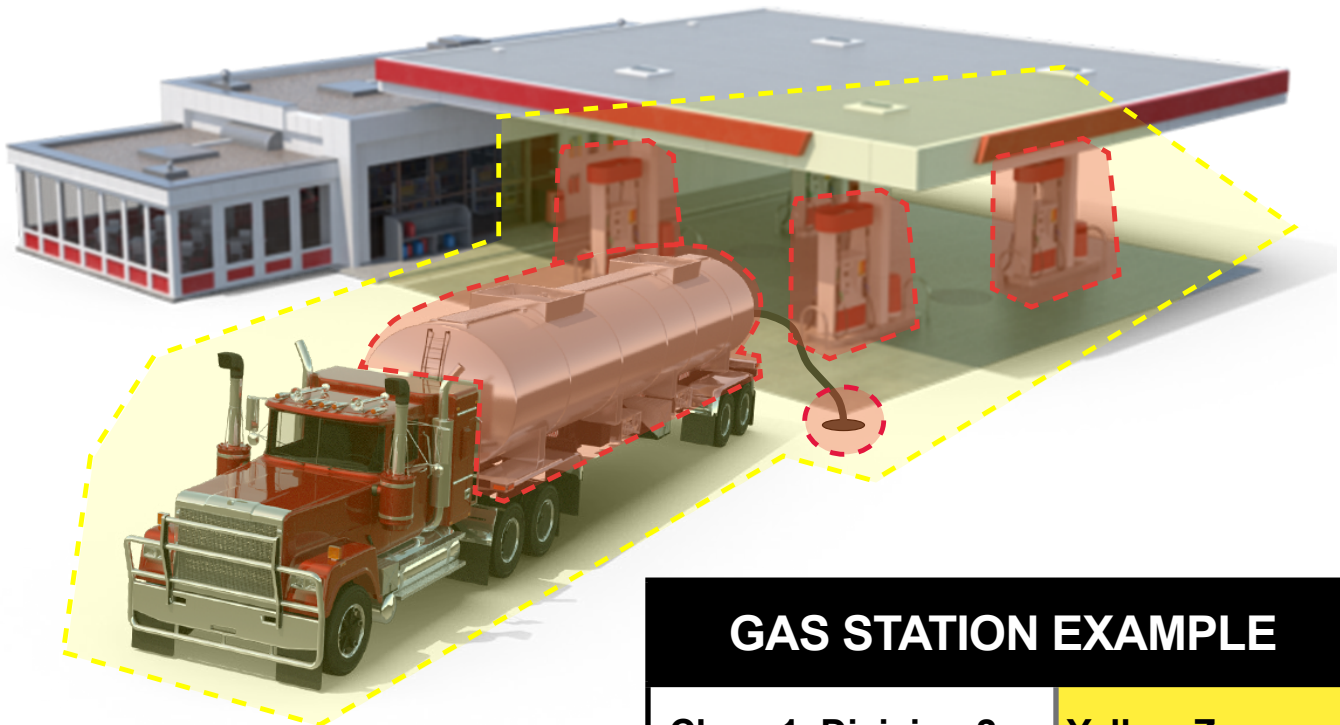



GAS STATION EXAMPLE	
Class 1, Division 2	Yellow Zone
Class 1, Division 1	Red Zone

Electric vs. Pneumatic Valve Actuators

The **Exlar Tritex EVA080** is a powerful and compact system integrated a servo drive, motor, and roller screw actuator to achieve extreme life, speed, and accuracy. Compare the benefits of an electric system over a pneumatic system.

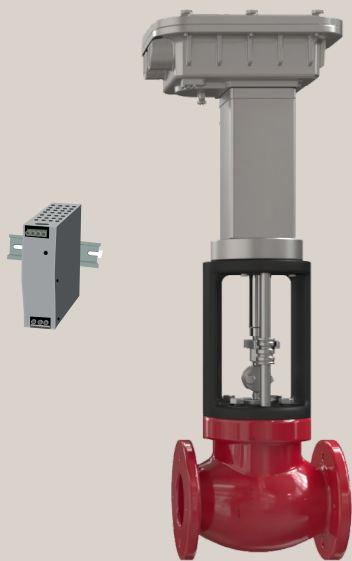
COMPARISON

	Electric System	Pneumatic System
Efficiency & Emissions		
Energy Usage:	Low	High
Green-house Emissions:	Zero-Emissions	High
Cost		
Actuator Price:	Higher than pneumatic	Lower actuator cost
System Price:	Low, power wiring, power supply	High, air supply, piping, pneumatic valves, etc.
Installation Labor Price:	Low	High
Performance		
Time to Open/Close:	As little as a second; speed does not affect actuator life	As fast as several seconds, quick speeds negatively affect system life
Installation Footprint:	Compact, light weight	Large, complex, and heavy
Controllable Thrust/Speed:	Programmable speed, position, thrust	Very limited
Commissioning:	Easy-to-use Expert PC tool	Complicated system install
Fail-safe Mode:	Possible with 3rd party components	Not easily possible
System Construction:	Robust design	Fragile components, sensitive to vibration
Onboard Diagnostics:	Yes	No
Maintenance		
Repair & Replace:	Field serviceable, spares available	Low maintenance efficiency, specialized parts
Ongoing Maintenance:	Minimum system components for minimum maintenance	Maintain fittings, hoses, compressor, supporting air components, mechanical wear
		

Key Product Advantages

With the **Exlar Tritex EVA080**, you can increase your revenue and eliminate emissions with state-of-the-art electric valve actuation. The Tritex EVA080 electric valve actuator is a new solution for separators, plunger lift, injection pumps, and other well head valve applications

By eliminating the need to vent the natural gas to the atmosphere, this valve actuator is environmentally friendly and efficient. This powerful and compact system integrated a servo drive, motor, and roller screw actuator to achieve extreme life, speed, and accuracy.

Environmental Compliance - Green Technology



- Zero-emissions, no-vent, no-bleed, intelligent electric valve actuation solution
- Suitable for Hazardous Location installation with Class 1, Division 2 certification
- Remote operation and monitoring with Modbus RTU (RS-485)

Performance



- Fast valve strokes in as little as a second
- Servo design allows for valve jam protection with up to 150% seating force, exceeding 150% will halt operation
- Absolute position sensing for increased control even with power loss
- Low-power requirements suitable for solar or grid power

Low Maintenance



- Roller screw drive train for unparalleled reliability and actuator life
- Extend valve life with advanced valve seating control to minimize thrusts & speeds
- Compact overall footprint allows for greater installation flexibility



TRITEX EVA080 ZERO EMISSIONS

Tritex EVA Product Information

PRODUCT INFORMATION

Features & Benefits

1 Easy Installation & Low Maintenance

- Non-intrusive commissioning with M8 IP67 sealed connector
- Face mount to detachable valve mount kits to fit a wide variety of industry standard valves for easy mounting
- Extended life lubrication can be mounted in any orientation
- Exceeds ISO 22153 Class D endurance requirements for a long-lasting electric valve actuator (10+ million cycles, 3600+ starts per hour)*

2 Certified for hazardous locations

- CSA certified for Class 1 Division 2, Group A, B, C, D suitable for hazardous locations where gas is not present under normal operation

3 Environmental Protection

- Rated NEMA 4X, IP66 with field replaceable double rod seal design for outdoor environments in a wide variety of climates
- Wide range of operational temperatures: -40 - 149 °F (-40 - 65° C) for low temperature operation without the use of a heater

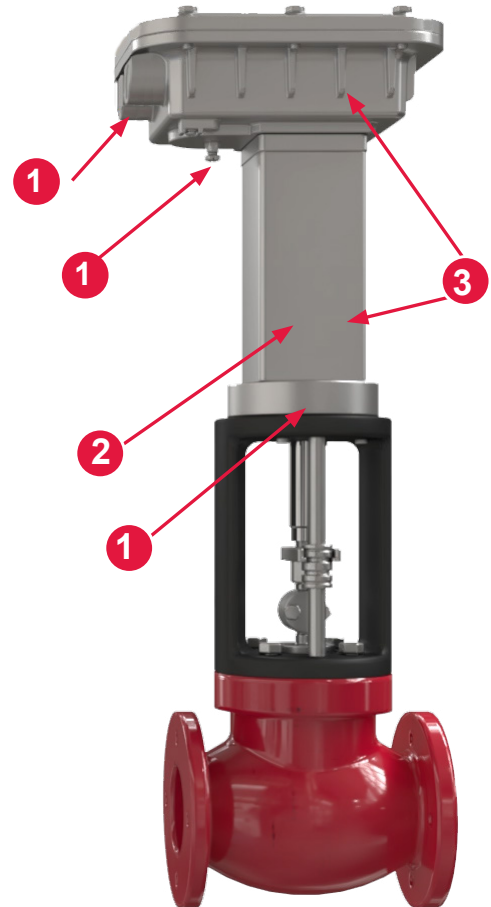

Connection Basics

1 Easy Installation & Low Maintenance



- Tool-free lever lock / push-in terminals for easy wiring
- Large terminal can accept 10-14 AWG wire
- 9-24 Vdc input Voltage for grid-power or solar-power

2 Application Flexibility & Control



- Modbus RTU (RS-485) communications for remote diagnostics & control
- 4-20 mA input & output for position or thrust control
- Isolated 24 Vdc (10-30 Vdc) digital inputs / outputs for position control & feedback

3 Field Serviceable



- Field replaceable PCB to limit unplanned downtime
- Field replaceable power-loss position tracking back-up battery option

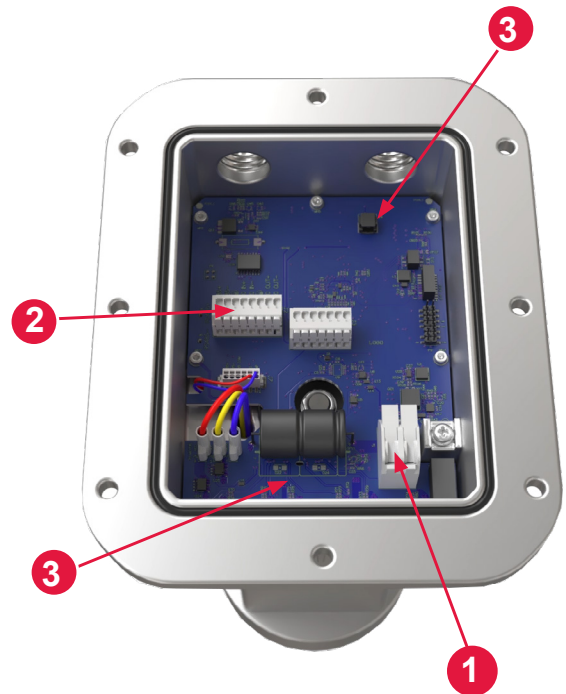



Expert Software

Expert Software

EXPERT™

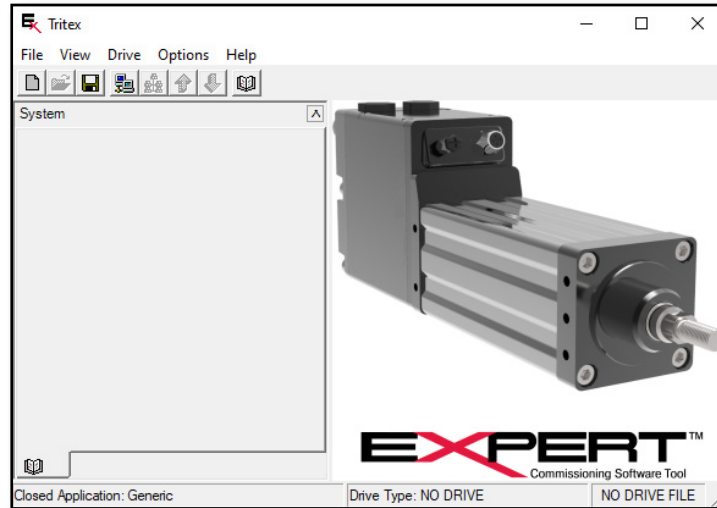
Commissioning Software Tool



- 1 Enhanced Application Control**  
- Programmable valve stroke, speed, & thrust control
 - Fail-safe position on low bus voltage
 - 4-20 mA, digital IO, & Modbus RTU (RS-485) control
 - Extend valve life with optimized seating thrust

- 2 Onboard Diagnostics** 
- Last 10 fault log
 - Local or remote monitoring of:
 - Actuator temperature
 - Input power (current draw & bus voltage)
 - Valve stroke position
 - Fault conditions
 - Real-time valve actuator performance (remote/local)

Valve Adapter Kit

- available from Motion Express



Easy Installation

- 1** Face mount to detachable valve mount kits to fit a wide variety of industry standard valves for easy mounting
 - DynaFlo, Kimray, Norriseal, Fisher, more
- 2** Self-aligning assembly
- 3** Built-in actuator anti-rotate assembly
- 4** Corrosion resistant and wide temperature range design suitable for the harshest environments (-100 °F to 200 °F)
 - Matte black powder coat finish
 - Stainless steel stem adapter
 - Zinc plated hardware

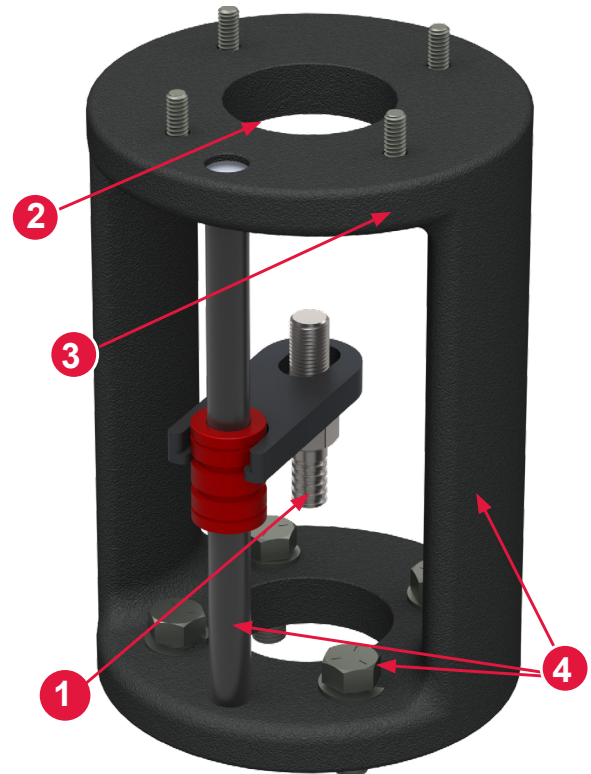

Valve Adapter Kit

Purchase Instructions:

- Contact Motion Express for availability
Phone: 720.346.7305
- <https://motionexpressinc.com/>

Speed & Endurance

Based on nearly 30 years of electric valve actuation experience the Tritex EVA is the clear leader in actuation life & performance. In a typical application the EVA is expected to last **9 times longer** than the industry standard of 10,000,000 cycles outlined in ISO 22153.

Valve Stroke	Time to Open/Close	Cycle Time	Life (cycles)*
0.5 in	1 s	2 s	135 Million
0.75 in	1.125 s	2.25 s	89 Million
1 in	1.725 s	3.45 s	67 Million
1.5 in	2.25 s	4.5 s	45 Million
4 in	6 s	12 s	18 Million

*Based on a full open/close cycle with rated thrust as defined by ISO 22153

Cycle consists of full open and close

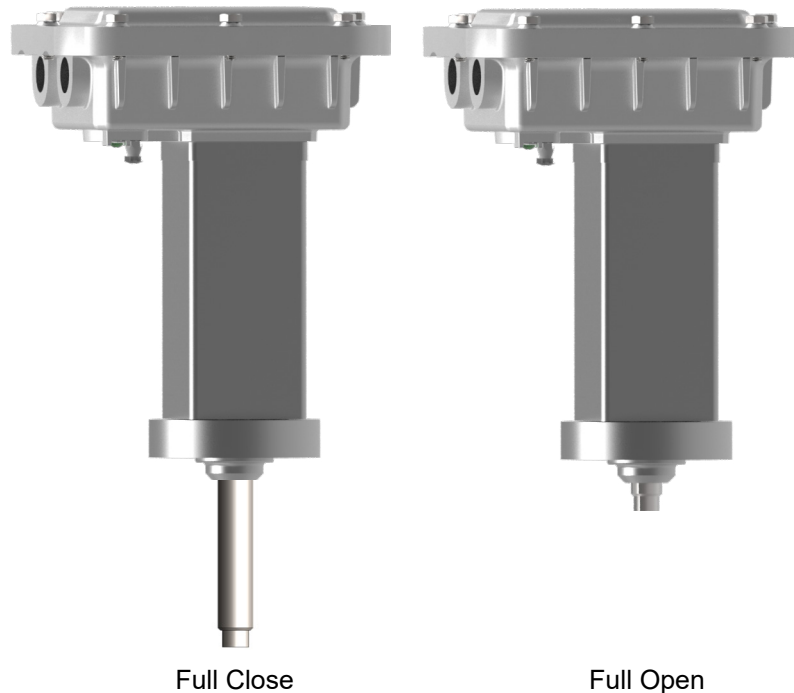

Electric Valve Actuator Selection & Thrust Load

Selection Parameters

- If the following information is unknown the Tritex EVA080 can be selected based on its rated thrust.
- If the following information is known, an advanced sizing can be done utilizing the full seating thrust capabilities of the actuator
- Valve parameters
 - Valve manufacturer, type, size, function
 - Valve thrust (seating/unseating, dynamic thrust)
 - Maximum allowable stem thrust limitation (MAST)
 - Maximum permissible thrust applied to drive train
 - Safety factor
 - Valve travel / stroke
 - Operating environments

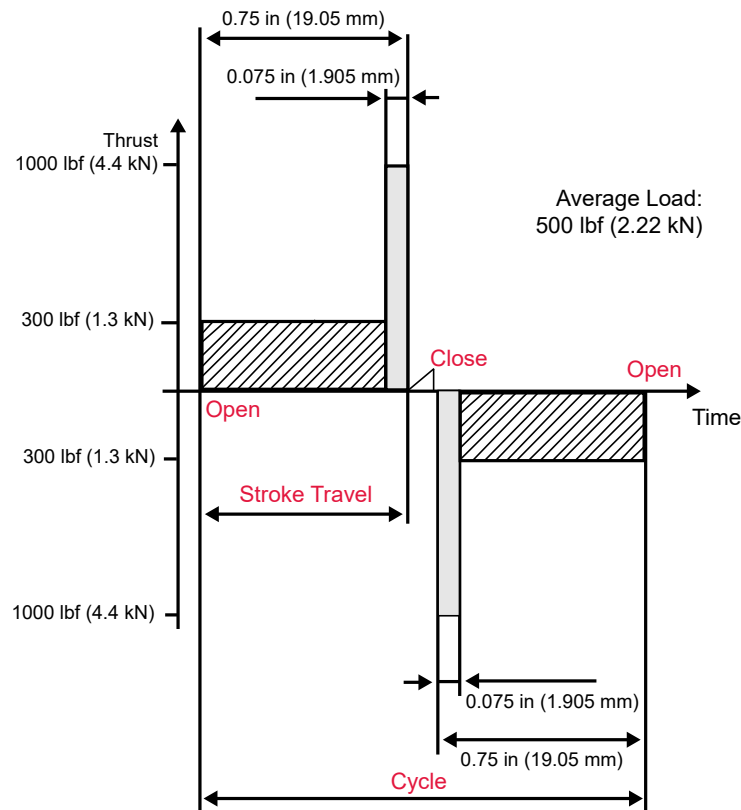

Dimensions

Dimensions

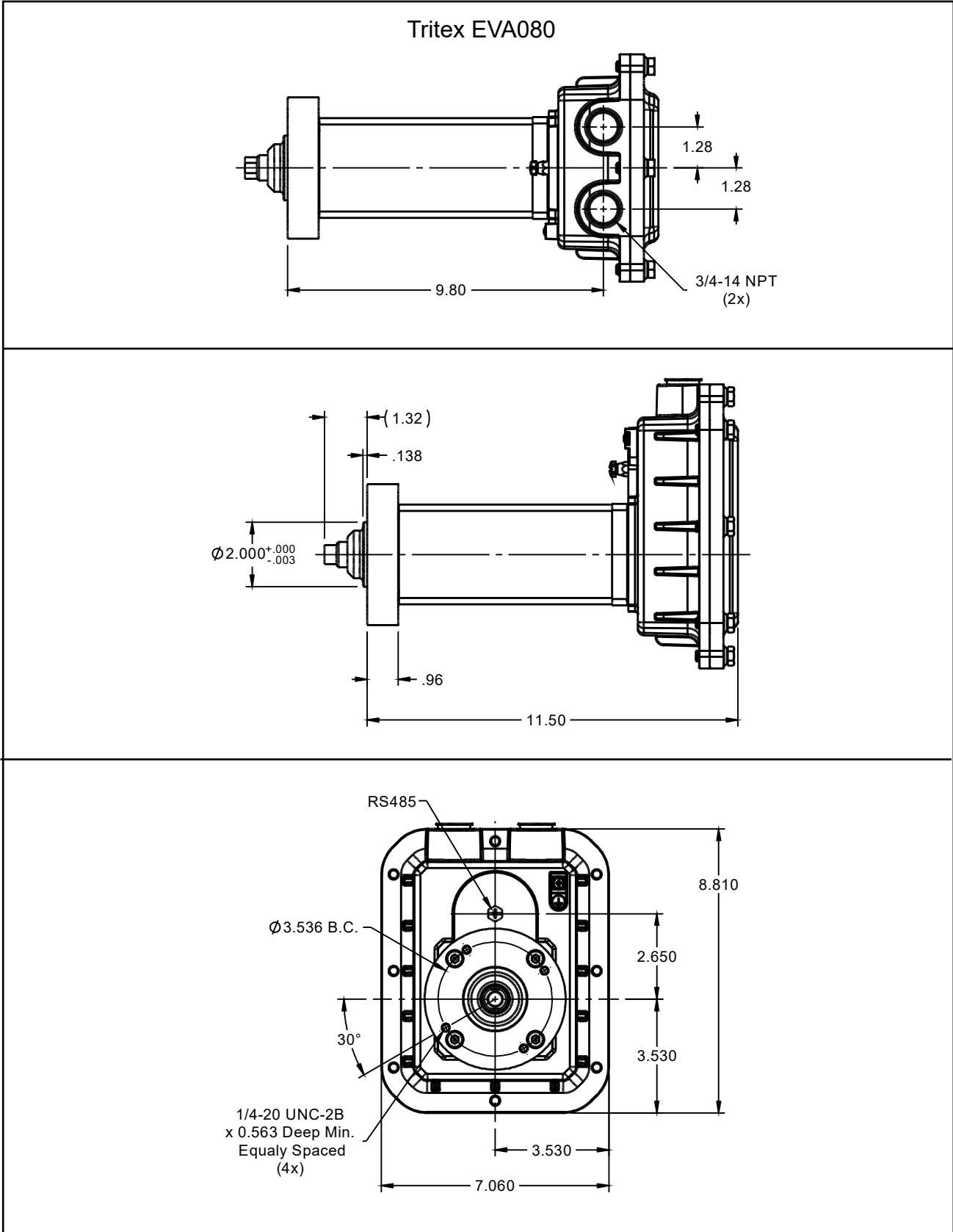

Product Specifications

Power & Control	
Rated Thrust	1000 lbf (4.4 kN)
Seating Thrust ISO Rated Thrust	1500 lbf (6.67 kN)
Speed	1 in/s (24.4 mm/s) @ 24 Vdc
Stroke Length	4 in (101.6 mm)
Input Voltage	12-24 Vdc nominal, 9-32 Vdc max range
Input Current	10 A @ rated thrust, 1 A @ nominal thrust
Endurance & Life	
Endurance	10,000,000 + starts, 3600+ starts per hour
Duty	Class D continuous modulating, 100% duty cycle
Life (Dynamic Load Rating)	5,516 lbf (24.5 kN)
Communication & Commissioning	
Serial Interface	Isolated Modbus RTU (RS-485), max baud rate 38.4 k
Software Tool	Free-to-download Expert PC commissioning tool
Inputs & Outputs	
Digital Inputs	3 - Isolated, 9-30 Vdc
Digital Outputs	2 - Isolated, 9-30 Vdc
Analog Input	1 - Isolated, 4-20 mA, position / thrust demand 0.1% resolution 0.5% linearity over temperature range
Analog Output	1- Isolated, 4-20 mA, position / thrust feedback 0.1% resolution, 0.5% linearity over temperature range
Environmental & Mounting	
Enclosure	NEMA 4X, IP66
Operating temperature	-40 to 149 °F (-40 to 65 °C)
Ambient storage temperature	-58 to 185 °F (-50 to 85 °C)
Mounting	Face mount, any orientation, with valve adapter
Noise	Less than 70 dB operation
Weight	17.2 lbs (7.8 kg)
Standards	
Approvals	CSA Class 1, Division 2, Group A, B, C, D, T5
Product Standards	ISO 22153, RoHS

Upstream Oil & Gas Applications

The performance capabilities of the Tritex EVA080 make it suitable for nearly any upstream oil & gas application. Its fast valve close times, long life, and low maintenance make the Tritex EVA080 a solution oil field operators can trust and rely upon.

Some of the applications that the Tritex EVA080 is ideally suited for includes:

- Oil & Gas Wellhead Valve Control
- Pipeline Valve Control
- Damper Control
- Knife Valve Control
- Separators (see example below)
- Chemical Pumps
- Plunger Lifts
- Injection Pumps
- And more!

APPLICATIONS

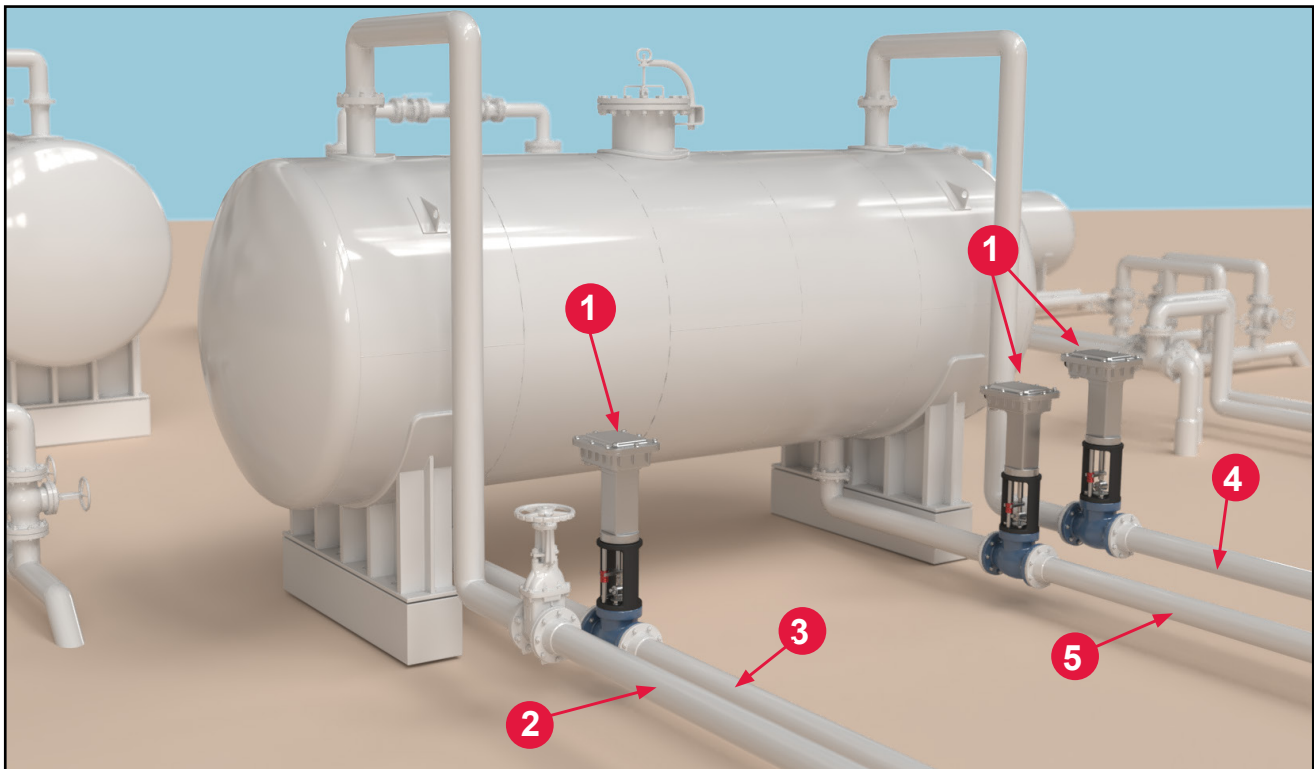

Horizontal Separator

- ❶ Tritex EVA080 Electrically Actuated Valves
- ❷ Crude Oil Inlet
- ❸ Separated Water
- ❹ Separated Gas
- ❺ Separated Oil

Ordering Information

ORDER INFORMATION

Sample Product Number: EVA080-100-01-B-AA-H-R

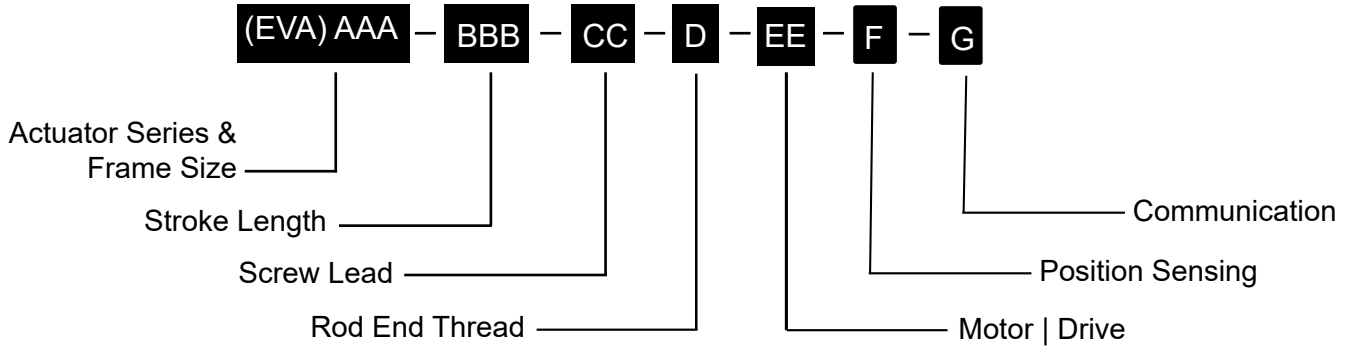

Actuator Series
EVA = Electric Valve Actuator, Linear

AAA = Actuator Frame Size
080 = 80 mm (3.1 in)

BBB = Stroke Length
100 = 100 mm (4 in)

CC = Screw Lead
01 = 2.54 mm (0.1 in), Roller Screw

D = Rod End Thread
B = Female Metric, M12x1.25

EE = Motor | Drive
AA = Standard Motor (A), Standard Servo Drive (A), 12-24 Vdc Input

F = Position Sensing
A = Absolute Position Sensing on Power Loss

G = Communication
R = Standard Modbus RTU (RS-485)

USA & CANADA

Curtiss-Wright, Exlar

18400 West 77th Street

Chanhassen, MN 55317

Phone: 855-620-6200 (US & Canada)

Fax: 952-368-4877

EXLAR[®]

www.Exlar.com

Exlar[®] and Tritex[®] are brands Curtiss-Wright